

Joint Oil Data Initiative Manual



www.jodidata.org



Asia-Pacific
Economic Cooperation



Joint Oil Data Initiative Manual



INTERNATIONAL ENERGY FORUM SECRETARIAT (IEFS)

The 10th IEF Ministerial and 2nd International Energy Business Forum took place in Doha, Qatar, co-hosted by China Italy, on 22-24 April 2006 and confirmed Energy Security as a "Shared Responsibility". The 11th IEF and 3rd IEBF will be hosted by Italy in Rome in 2008 with India and Mexico as co-hosts.

The IEF Secretariat is an inter-governmental entity established in December 2003 with Headquarters in Riyadh, Saudi Arabia. Its mission is to enhance and provide continuity to the global producer-consumer dialogue at the level of Ministers in the IEF. The Secretariat also serves as coordinator of the Joint Oil Data Initiative with the support of APEC, Eurostat, IEA, OLADE, OPEC and UNSD. Its activities are funded on the basis of annual voluntary contributions from some sixty key energy producing and consuming countries.

The objectives of the Secretariat are:

- To foster the concept of interdependency by presenting the opportunity and creating the atmosphere for dialogue between oil and gas producing countries, as well as dialogue between governments and energy related industries;
- To provide platforms to promote the study and exchange of views on the inter-relationship between energy, technology, environmental issues, economic growth and development; and
- To promote the role of stable and transparent energy markets for the health of the world economy, security of energy supply and demand, the expansion of global trade and investment in energy resources and technology.

ASIA PACIFIC ECONOMIC COOPERATION (APEC)

APEC is an intergovernmental grouping operating on the basis of non-binding commitments, open dialogue and equal respect for the views of all participants. It was established in 1989 to further enhance economic growth and prosperity for the region and to strengthen the Asia-Pacific community.

APEC's 21 Member Economies are Australia; Brunei Darussalam; Canada; Chile; People's Republic of China; Hong Kong, China; Indonesia; Japan; Republic of Korea; Malaysia; Mexico; New Zealand; Papua New Guinea; Peru; The Republic of the Philippines; The Russian Federation; Singapore; Chinese Taipei; Thailand; United States of America; and Viet Nam.

Since its inception, APEC has worked to reduce tariffs and other trade barriers across the Asia-Pacific region, creating efficient domestic economies and dramatically increasing exports. Key to achieving APEC's vision are what are referred to as the 'Bogor Goals' of free and open trade and investment in the Asia-Pacific by 2010 for industrialised economies and 2020 for developing economies. These goals were adopted by Leaders at their 1994 meeting in Bogor, Indonesia.

APEC's energy issues are the responsibilities of the Energy Working Group (EWG), one of its 11 working groups. The development and maintenance of the APEC Energy Database is assigned to EWG's Expert Group on Energy Data and Analysis (EGEDA) who has appointed the Energy Data and Modeling Center (EDMC) of the Institute of Energy Economics, Japan (IEEJ) as Coordinating Agency. One of the objectives of EGEDA is to collect monthly oil data of the APEC economies in support of Joint Oil Data Initiative.

Applications for permission to reproduce or translate all or part of this publication should be made to:
IEF Secretariat, Diplomatic Quarter, P.O. Box 94736, Riyadh 11614, Saudi Arabia.

INTERNATIONAL ENERGY AGENCY (IEA)

The International Energy Agency (IEA), is an autonomous body which was established in November 1974 within the framework of the Organisation for Economic Co-operation and Development (OECD), to implement an international energy programme. It carries out a comprehensive programme of energy co-operation among twenty-six of the OECD's thirty member countries. The basic aims of the IEA are:

- To maintain and improve systems for coping with oil supply disruptions;
- To promote rational energy policies in a global context through co-operative relations with nonmember countries, industry and international organisations;
- To operate a permanent information system on the international oil market;
- To improve the world's energy supply and demand structure by developing alternative energy sources and increasing the efficiency of energy use;
- To assist in the integration of environmental and energy policies.

The IEA member countries are: Australia, Austria, Belgium, Canada, the Czech Republic, Denmark, Finland, France, Germany, Greece, Hungary, Ireland, Italy, Japan, the Republic of Korea, Luxembourg, the Netherlands, New Zealand, Norway, Portugal, Spain, Sweden, Switzerland, Turkey, the United Kingdom, the United States. The European Commission takes part in the work of the IEA.

EUROSTAT

Eurostat is the Statistical Office of the European Communities. Its task is to provide the European Union with statistics, at a European level, that allow comparisons to be made between countries and regions. Eurostat consolidates and harmonises the data collected by the Member States. To ensure that the vast quantity of accessible data is made widely available and to help each user make proper use of the information, Eurostat has set up a publications and services programme. This programme makes a clear distinction between general and specialist users and particular collections have been developed for these different groups. The collections Press releases, Statistics in focus, Panorama of the European Union, Pocketbooks and Catalogues are aimed at general users. They give immediate key information through analyses, tables, graphs and maps. The collections Methods and nomenclatures and Detailed tables suit the needs of the specialist who is prepared to spend more time analysing and using very detailed information and tables. As part of the new programme, Eurostat has developed its web site. It includes a broad range of online information on Eurostat products and services, newsletters, catalogues, online publications and indicators on the euro zone.

THE LATIN-AMERICAN ENERGY ORGANISATION (OLADE)

The Latin-American Energy Organisation (OLADE) is an international public entity of cooperation, coordination and advising. Its fundamental purpose is integration, protection, conservation, defense and rational use of energy resources of the Region.

The fundamental objectives of the organisation are as follows:

- Politic and technical tool for prompting better regional energy integration.
- Manage official statistics, products and services and regional energy planning
- Encourage training inside the Energy Ministries of the Member Countries.
- Promote regional energy cooperation among countries.

Member Countries: Argentina, Barbados, Bolivia, Brazil, Colombia, Costa Rica, Cuba, Chile, Ecuador, El Salvador, Grenada, Guatemala, Guyana, Haiti, Honduras, Jamaica, México, Nicaragua, Panama, Paraguay, Peru, Dominican Rep., Surinam, Trinidad & Tobago, Uruguay y Venezuela.

THE ORGANISATION OF PETROLEUM EXPORTING COUNTRIES (OPEC)

The Organisation of Petroleum Exporting Countries, OPEC is the organisation that coordinates and unifies the petroleum policies of the eleven developing oil producing nations that make up its membership. It seeks to ensure the stabilization of oil prices in international oil markets, with a view to eliminating harmful and unnecessary fluctuations, due regards being given at all times, to the interests of oil producing nations, and to the necessity of securing a steady income for them.

OPEC was formed on September 14, 1960, at a meeting in Baghdad, the Iraqi capital by five countries that became the founder members. It was registered with the United Nations Secretariat on November 6, 1962, following UN Resolution No. 6363. Also in attendance at the Baghdad meeting were– Islamic Republic of Iran, Iraq, Kuwait, Saudi Arabia and Venezuela. They signed the original agreement establishing OPEC. Today, the organisation has eleven members namely, Algeria, Indonesia, Nigeria, Qatar, Saudi Arabia, United Arab Emirates, IR Iran, Iraq, Kuwait, SP Libyan AJ and Venezuela.

The principal aims of the Organisation as outlined in Article 2 of its statute are:

1. The co-ordination and unification of the petroleum policies of Member Countries and the determination of the best means for safeguarding their interests, individually and collectively.
2. Devising ways and means of ensuring the stabilization of prices in international oil markets with a view to eliminating harmful and unnecessary fluctuations, while
3. Giving due regard at all times, to the interests of the producing nations and to the necessity of securing a steady income to the producing countries; an efficient, economic and regular supply of petroleum to consuming nations; and a fair return on their capital to those investing in the petroleum industry.

UNITED NATIONS STATISTICS DIVISION (UNSD)

The United Nations Statistics Division (UNSD), collects, processes and disseminates statistical information on demography, energy, environment, industry statistics, international trade, national accounts, social and housing statistics.

UNSD started collecting energy statistics regularly in 1950. It has made efforts to help users responsible for energy policy to collect data from the energy industry and other players in the energy production and distribution system; in providing information mainly on production, supply and consumption of energy by fuel type and also other characteristics relating to the size and capabilities of the different industries (mines, oil producers, refineries and distributors, electrical power statistics, households). UNSD's main data suppliers are the statistical organisations of the countries and the energy authorities responsible for petroleum, natural gas, mines, electricity or the whole economy.

Currently, UNSD collects energy statistics from more than 190 countries and the main publications on energy statistics are: *the Energy Statistics Yearbook* and *the Energy Balances and Electricity Profiles*. UNSD is also involved in developing concepts and methods in the domain of energy statistics, to ensure international comparability of energy data and organise regional seminars and workshops in order to enhance national statistical capacity building in energy statistics.

UNSD is being involved in the work of the Oslo Group on Energy Statistics; a forum where countries discuss methodological issues, learn from good practices and contribute to the methodological development of energy statistics, and work on harmonization which can support the compilation of energy statistics produced on international level

UNSD is playing an active role in international cooperation in the area of energy statistics with the following agencies: IEA/OECD, EUROSTAT, OPEC, World Energy Council, APEC, International Sugar Organisation, other inter-governmental organisations (IGOs) and NGOs. It also, co-operates with the United Nations regional commissions, the International Atomic Energy Agency (IAEA), the Food and Agricultural Organisation (FAO) and other specialized agencies.

Foreword

The Joint Oil Data Initiative, JODI, is a concrete outcome of the producer consumer dialogue. JODI is international ambition translated into action with the objective of improving the quality and transparency of international oil statistics that are important for investments and energy security.

More than 90 countries, representing more than 90% of global oil supply and demand, are now submitting data to JODI. The data cover production, demand and stocks of seven product categories: crude oil, LPG, gasoline, kerosene, diesel oil, fuel oil and total oil. For many countries, especially the top 30 producers and consumers, timeliness, coverage and reliability are already at reasonable levels.

The JODI World Database was released to the public in November 2005 by King Abdullah of Saudi Arabia in the presence of Ministers of key energy producing and consuming countries.

Support from Ministers to the Joint Oil Data Initiative was reaffirmed at the 10th IEF which took place in Doha, Qatar in April 2006. In July 2006, G8 Heads of Government emphasized in their St. Petersburg Plan of Action, the importance of this global and inter-organisational transparency initiative.

JODI is promising work in progress with great potential. The success of the initiative will be determined by the collective ability of all stakeholders to sustain and improve their efforts. The submission of timely and accurate data by participating countries is crucial for its success.

To help enhance the quality of data, the IEF Secretariat will, in cooperation with partner organisations, organise regional training sessions on JODI and energy statistics. The first such regional JODI training workshop took place in Caracas, Venezuela in August 2006 for Latin American countries. Others will follow.

This Manual was prepared jointly by IEFS and its JODI partners (APEC, Eurostat, IEA, OLADE, OPEC and UNSD). Our objective is to help data collectors and users understand the methodology and definitions used in the JODI questionnaire. Along with training sessions on JODI conducted by IEFS and partner organisations, this Manual will help data collectors to conduct basic verification of data, avoid common reporting errors and share examples of practices.

The JODI Manual is another step on the road to higher quality of oil data and more transparent markets.

Ambassador Arne Walther
Secretary General
International Energy Forum

Acknowledgements

This manual was prepared jointly by the Energy Division of the International Energy Forum Secretariat (IEFS) and its partners in the Joint Oil Data Initiative (JODI)- the Asia Pacific Economic Cooperation (APEC), the Statistical Office of the European Communities (Eurostat), the International Energy Agency (IEA), the Latin American Energy Organisation (OLADE), the Organisation for Petroleum Exporting Countries (OPEC), and the United Nations Statistics Division (UNSD).

The ongoing success of JODI relies on the sustained and active participation and support of all key actors. Therefore, special acknowledgement is due to Argentina, Croatia, Egypt, France, Norway, Philippines, and Saudi Arabia, the countries whose case studies appear in the manual. Thanks are also due to the many other participating countries that volunteered material for publication: Algeria, Bulgaria, Costa Rica, Cyprus, Estonia, Latvia, Lithuania, Mexico, Romania, Sweden and Uruguay. The depth of the material submitted has added considerable value to the development of the JODI training programme as well as to the comprehensiveness of the manual.

The JODI continues to evolve and this publication is a living document. Feedback is an essential element in the drive for progress and comments on the Initiative are actively encouraged. Please submit questions or observations on the implementation of JODI via email to [\[jodinfo@iefs.org.sa\]](mailto:jodinfo@iefs.org.sa).

Table of Contents

Foreword	v
Acknowledgements	vii
Preface	1
1. Introduction	3
2. The JODI Questionnaire	5
2.1 The Questionnaire.....	5
2.2 Instructions for Completion	5
2.3 Definitions.....	6
3. Product Definitions.....	7
3.1 Crude Oil.....	7
3.2 LPG (Liquefied Petroleum Gases).....	9
3.3 Gasoline	12
3.4 Kerosene.....	14
3.5 Gas/Diesel Oil.....	16
3.6 Heavy Fuel Oil.....	18
3.7 Total Oil Products.....	20
4. Flow Definitions	21
4.1 Production (Crude Oil)	21
4.2 Imports and Exports.....	23
4.3 Closing Stocks	26
4.4 Stock Changes.....	31
4.5 Refinery Intake.....	33
4.6 Refinery Output.....	35
4.7 Demand.....	37
5. Verification of Data Quality	39
5.1 Data Quality Assessment.....	39
5.2 Focus on Data Accuracy.....	40
5.3 Monthly versus Annual Data	48
5.4 Common Reporting Errors.....	50
6. Estimations and Revisions of Data.....	53
6.1 Estimations.....	53
6.2 Revisions.....	59
7. Examples of Practices – A few Examples of JODI Data Collection and Methodology in Member Countries.....	61
7.1 Argentina (data submitted to OLADE)	61
7.2 Croatia (data submitted to EUROSTAT).....	63

7.3	Egypt (data submitted to UNSD)	64
7.4	France (data submitted to IEA)	66
7.5	Norway (data submitted to IEA)	68
7.6	Philippines (data submitted to APEC)	71
7.7	Saudi Arabia (data submitted to OPEC)	75
8.	The JODI World Database	77
8.1	Background	77
8.2	Building the JODI World Database	77
8.3	The JODI World Database	78
8.4	Possible Future Expansion	80
<i>Annex 1:</i>	<i>The Refinery Process</i>	<i>81</i>
<i>Annex 2:</i>	<i>Units and Conversion Factors</i>	<i>85</i>
	List of Abbreviations	91
	Contact Details	93
	List of Figures	
Figure 3.1	Production of LPG	9
Figure 4.1	Wellhead versus Marketed Production	21
Figure 4.2	Main Refinery Flows	35
Figure 4.3	Demand Flows	37
Figure 5.1	Refinery Intake Volumes	47
Figure 7.1	Downstream Oil Sector	71
Figure 8.1	Relationship between the IEFS, International Organisations and Countries	78
Figure 8.2	A View from the Database	79
Figure A1.1	Operation of a Typical Refinery	81
	List of Tables	
Table 5.1	Example 1 of Internal Balance Check	41
Table 5.2	Example 2 of Internal Balance Check (where deviation is justified)	42
Table 5.3	Example 1 of Fuel Balance Check	43
Table 5.4	Example 2 of Fuel Balance Check	44
Table 5.5	Example of Checking Consistency of Stocks Data	45
Table 5.6	Comparing Growth Rate for the Latest Month to the Historical Trend	46
Table 6.1	Annual Balance for Country Z	54
Table 6.2	Monthly JODI data for Country Z	55
Table 6.3	Refinery Output of Gas/Diesel Oil of Country Z	56
Table 6.4	How to Estimate Missing Data – Example 1	57
Table 6.5	How to Estimate Missing Data – Example 2	57
Table 6.6	How to Estimate Missing Data – Example 3	58
Table A2.1	Most Common Multiple and Sub-multiple Prefixes	85
Table A2.2	Conversion Equivalents between Units of Volume	86
Table A2.3	Conversion Equivalents between Units of Mass	86
Table A2.4	Conversion Equivalents between Units of Energy	87
Table A2.5	Typical Densities, Conversion Factors and Calorific Values for Crude Oil and Petroleum Products	89
Table A2.6	Example of Converting Volume to Mass	89

Preface

The end of the 1990s was characterized by unusually high volatility of oil prices. The lack of transparent and reliable oil statistics was identified as a contributory factor to the volatility. This is in addition to externalities including political tension and economic shocks. Efforts to improve the availability and reliability of oil data began among producers and consumers, who recognized the need for more data transparency in the oil market. Ministers at the 7th International Energy Forum in Riyadh in 2000 made clear their support for better data and urged a global response to the challenge.

Evolution from the 7th to 10th International Energy Forum: From an Exercise to an Initiative and a Database

Six international organisations – APEC, Eurostat, IEA, OLADE, OPEC and UNSD* – took up the challenge, combined their efforts, involved their Member Countries and in April 2001 launched the **Joint Oil Data Exercise (JODE)**. The primary goal was not to build a database, but to raise the awareness of all oil market players to the need for more transparency of oil market data.

The first priority of the six organisations was to assess the oil data situation in their respective member countries in order to better qualify and quantify the perceived lack of transparency. The assessment included the collection of up-to-date monthly oil statistics from each organisation's member countries through a harmonized questionnaire on 42 key oil data points.

Progress was immediate: Within six months, 55 countries were already participating in the exercise. Six months later there were over 70 participating countries, representing 90 per cent of global oil supply and demand. At the 8th International Energy Forum in Osaka in 2002, Ministers commended the work, reaffirmed their political support and urged the organisations to redouble their efforts.

Having obtained the political mandate to reinforce their work, the six organisations obtained agreement from their Member Countries to make the Exercise a permanent reporting mechanism; the Exercise was then renamed the **Joint Oil Data Initiative (JODI)**.

As the process gathered momentum, more countries participated and their submissions became more timely, complete, and of higher quality. It became, therefore, desirable to assemble all the information in a compatible form: The **JODI World Database** was born.

Participants in the 5th JODI Conference in October 2004 strongly recommended that this joint global database be made freely accessible to all – organisations, countries, industry, analysts and others.

* Asia Pacific Economic Cooperation (APEC), Statistical Office of the European Communities (Eurostat), International Energy Agency (IEA), Latin-American Energy Organisation (OLADE), Organisation of Petroleum Exporting Countries (OPEC), United Nations Statistics Division (UNSD)

From Concept to Launch

Transparency does not happen overnight and despite the significant progress achieved since its inception, the database is still far from perfection. The IEF Secretariat, which took over the co-ordination of JODI in January 2005, and the six partner organisations are fully aware of the limits and limitations of the database at this stage of its development. However, since transparency is central to the initiative, the organisations responded positively to the request expressed at the 5th JODI Conference for the database to be made accessible to the public.

In October 2005, the organisations agreed to open the JODI World Database. The database was officially launched on the occasion of the inauguration of the IEFS Headquarters building in Riyadh, by King Abdullah of Saudi Arabia on 19 November 2005.

A continuous process...

The database is and always will be work in progress. Timeliness, sustainability and completeness can always be improved upon, but the quality of data also constitutes an essential element of a good database.

The organisations therefore, jointly decided that several measures could be taken to help national administrations further enhance data quality when completing the JODI questionnaire. As a point of departure, it is essential that a manual be made available with the necessary guidelines and technical instructions; moreover, there is a concrete requirement for proper training sessions for statisticians in national administrations, as well as a user-friendly, effective and up-to-date website.

The ultimate goal of this initiative is full data transparency - a complete and comprehensive database with good quality data, updated on a timely basis and providing an overview of the global oil situation. We hope that the publication of this manual brings us a little closer to achieving this objective.

1. Introduction

The purpose of this manual is to provide data collectors and users with a full explanation of the methodology and definitions used in the Joint Oil Data Initiative (JODI) questionnaire. Moreover, it was deemed useful to supply some background information on how oil is produced, refined, etc.

At the outset of the JODI, when the questionnaire was designed, the six international organisations involved in the initiative at that time agreed to limit the number of data points requested in the JODI questionnaire to a minimum. The initial objective of the JODI indeed, was not to start a new data collection system, but to measure how many countries could submit monthly data on a regular basis. The JODI has evolved considerably since then and is now a permanent feature for the six organisations (more information is available on the JODI website: www.jodidata.org).

Only 42 key data points were requested: seven product categories (*crude oil, LPG, gasoline, kerosene, gas/diesel oil, fuel oil and total oil products*) and six flows (*production, imports, exports, stock changes, closing stocks and demand*). The information requested does not constitute a balance; for a complete oil balance to be reported, information on several other flows would be required (e.g. transfers, direct use, etc).

Similarly, in order to have a small and easily understandable questionnaire, the definitions were kept to a minimum, only the absolute essential was included in the definitions. Moreover, as the six international organisations were already collecting oil statistics for other purposes, each of them had developed definitions appropriate for their data collection. The idea was therefore that at the onset, definitions would be kept simple, and that more extensive definitions (based on harmonised definitions of the six organisations) would be developed as the initiative evolved.

Indeed, an informal working group was established to come up with harmonised definitions. This proved to be easier said than done. Hundreds of emails were exchanged just on the definition of crude oil production, ending up with a non-conclusive result. Harmonisation is an important issue and the project will be re-launched by the seven international organisations (this time including the IEFS which now acts as coordinator of the JODI) in the very near future. Given the magnitude of the task and the urgent need for a manual, it was decided that for this manual, the different definitions used by each of the six organisations would be shown, and although the definitions used by the organisations may be differently worded, the differences may not be so large that they result in dramatically different reporting. Nonetheless each national administration must adhere to the definitions of the organisation they belong to when they submit JODI data, with the exception of OLADE member countries which are requested to follow the JODI definitions reported in this manual.

This manual comprises eight chapters and two annexes. This chapter provides for an introduction; the JODI questionnaire is described in Chapter 2 and the product and flow definitions are addressed in Chapters 3 and 4, respectively. Data verification methodology is in Chapter 5, to guide the data providers in their efforts to improve data quality. Chapter 6 provides information on estimation and revision of data. Chapter 7 serves the data providers by giving real examples of data collection practices together with associated problems and solutions in various countries. Chapter 8 provides information on the JODI World Database. A brief overview of the refinery process is given in Annex 1, which can act as a quick reference for studying and checking the complicated interplay of products and flows in oil refineries. Annex 2 provides explanations about units and conversion factors which may be needed when submitting JODI data.

2. The JODI Questionnaire

The JODI questionnaire format, definitions and instructions on how to complete it are shown below. The questionnaire is to be submitted on a monthly basis. The format has not been revised since its inception in order to facilitate the completion of the questionnaire.

2.1 The Questionnaire

		Crude Oil	Petroleum Products					
			LPG	Gasoline	Kerosene	Gas/Diesel Oil	Fuel Oil	Total Oil Products
Production			Refinery Output					
Imports			Imports					
Exports			Exports					
Stocks	Closing		Stocks					
	Change		Change					
Refinery Intake			Demand					

2.2 Instructions for Completion

Instructions

Deadline for submission: 25th of each month

The excel form includes two worksheets: one for month M-1 and one for month M-2.

1. Please do not change the format of the excel form
2. Please make sure that you indicate the **correct data month** in the cell for Month:
3. Do not enter decimal numbers, but only include rounded numbers
4. *Please note:*

the flows : Refinery Intake and Demand, as well as the product Total Products are not the sum of the previous flows and products

5. For specific details, please see the worksheet on Definitions in this spreadsheet.

When completed, please save the excel file and send to: ... (organisation)

If you have other questions or wish for more information, please contact:(organisation)

2.3 Definitions



APEC/EUROSTAT/OECD-IEA/OLADE/OPEC/UNSD JOINT OIL DATA INITIATIVE

Description of Definitions

Time : **M-1** is Last Month, or the month previous to the current month.
: **M-2** is two months previous to the current month

DESCRIPTION OF PRODUCTS

- 1. Crude Oil** : Including lease condensate – excluding NGL
- 2. LPG** : Comprises propane and butane
- 3. Gasoline** : Comprises motor gasoline and aviation gasoline
- 4. Kerosene** : Comprises jet kerosene and other kerosene
- 5. Gas/Diesel Oil** : For automotive and other purposes
- 6. Heavy Fuel Oil** : Heavy residual oil / boiler oil, including bunker oil
- 7. Total Oil Products** : Categories (2) to (6) and all other petroleum products (refinery gas, ethane, naphtha, petroleum coke, white spirit &SBP, paraffin waxes, bitumen, lubricants and others). Demand for Total Oil includes crude oil

DESCRIPTION OF FLOW

- a. Production** : Marketed production, after removal of impurities but including quantities consumed by the producer in the production process
- b. Imports/Exports** : Goods having physically crossed the international boundaries, excluding transit trade, international marine and aviation bunkers
- c. Closing Stocks** : Represents the primary stock level at the end of the month within national territories; includes stocks held by importers, refiners, stock holding organisations and governments
- d. Stock Changes** : Closing minus opening level.
Positive number corresponds to stock build, negative number corresponds to stock draw
- e. Refinery Intake** : Observed refinery throughputs
- f. Refinery output** : Gross output (including refinery fuel)
- g. Demand** : Deliveries or sales to the inland market (domestic consumption) plus Refinery Fuel, plus International Marine and Aviation Bunkers. Demand for Total Oil includes Crude

3. Product Definitions

This chapter on product definitions and the following one on flow definitions are structured as follows: firstly, the definition in the JODI questionnaire is shown, as well as some explanatory notes. Then the different definitions used by the six organisations in charge of collecting the JODI data from their member countries participating in the Initiative are listed, followed by a summary of the differences in the definitions.

Although the differences in the definitions between the organisations may not be significant, national administrations are required to follow the definitions of the organisation to which they belong when they submit JODI data. Consequently, due to these differences in the definitions, sub totals shown in the JODI World Database may lead to small misinterpretations.

3.1 Crude Oil

Including lease condensate – excluding NGL

Petroleum is a complex mixture of liquid hydrocarbons, chemical compounds containing hydrogen and carbon, occurring naturally in underground reservoirs in sedimentary rock. Petroleum is normally found at considerable depths beneath the earth's surface, where under pressure, it is essentially liquid. At the surface and atmospheric pressure, petroleum comprises both natural gas and crude oil.

The word petroleum comes from the Latin word, *petra*, meaning rock, and *oleum*, meaning oil. The word "petroleum" is often interchanged with the word "oil". Broadly defined, it includes both primary (crude oil or unrefined) and secondary (refined) products.

Crude oil is the most important oil from which **petroleum products** are manufactured, but several other feedstock oils are also used to make oil products. There is a wide range of petroleum products manufactured from crude oil. Many are for specific purposes, for example, motor gasoline or lubricants; others are for general heat-raising needs, such as gas oil or fuel oil.

The quality of crude oil depends to a great extent on its density and sulphur content. The crude oils are classified as light, medium and heavy according to their density. Crude oils with high sulphur content (at least 2.5% sulphur) are sour, while sweet crudes have often less than 0.5% sulphur content.

The different definitions used by the six international organisations: [Crude Oil]

APEC, Eurostat and IEA: Crude oil is mineral oil of natural origin comprising a mixture of hydrocarbons and associated impurities, such as sulphur. It exists in the liquid phase under normal surface temperature and pressure and its physical characteristics (density, viscosity, etc.) are highly variable. This category includes field or lease condensate recovered from associated and non-associated gas where it is co-mingled with the commercial crude oil stream.

OLADE: Crude oil is a complex mixture of hydrocarbons of different molecular weights, in which there is a generally small fraction of compounds containing sulfur and nitrogen. The composition of the oil is variable and can be divided into three classes, according to the distillation residues, as paraffins, asphalts or a combination of both.

Oil is used as a raw material in refineries for processing and obtaining its derivatives. In specific cases, it is also used for final consumption in given industrial activities.

OPEC: Crude oil is technically defined as a mixture of hydrocarbons that exists in the liquid phase in natural underground reservoirs and remains liquid at atmospheric pressure after passing through surface separating facilities.

UNSD: Crude oil/petroleum: mineral oil consisting of a mixture of hydrocarbons of natural origin, yellow to black in color, of variable density and viscosity. Data in this category also includes crude mineral oils extracted from bituminous minerals (shale, bituminous sand, etc.). Data also includes lease (field) condensate which is recovered from gaseous hydrocarbons in lease separation facilities.

The critical issue is whether the volumes of NGLs, lease or field condensates and oils extracted from bituminous minerals are included. All organisations exclude NGLs from crude oil. Condensates are also excluded, as long as they can be separated from the commercial crude oil stream. Oils extracted from bituminous minerals are included under crude oil only by UNSD.

3.2 LPG (Liquefied Petroleum Gases)

Comprises propane and butane

Liquefied Petroleum Gas (LPG) is the generic name for commercial propane and commercial butane. It can be produced from natural gas processing plants or from refineries. (See figure 3.1)

LPG occurs naturally as gas at atmospheric pressure. It has the special property of becoming liquid at atmospheric temperature if moderately compressed and can easily be converted from liquid into gas by being released to atmospheric pressure. In order to facilitate transport and storage, LPG is usually bottled in liquid state (about 250 times more dense than in its gaseous form), propane however can also be supplied in bulk for storage tanks at consumers' premises.

LPG is used domestically, mainly for heating and cooking purposes and industrially, for example as feedstock by the Petrochemical industry. It is also increasingly used in the transport sector as vehicle fuel, because of its cleaner burning properties and often lower end-use price.

Figure 3.1: Production of LPG

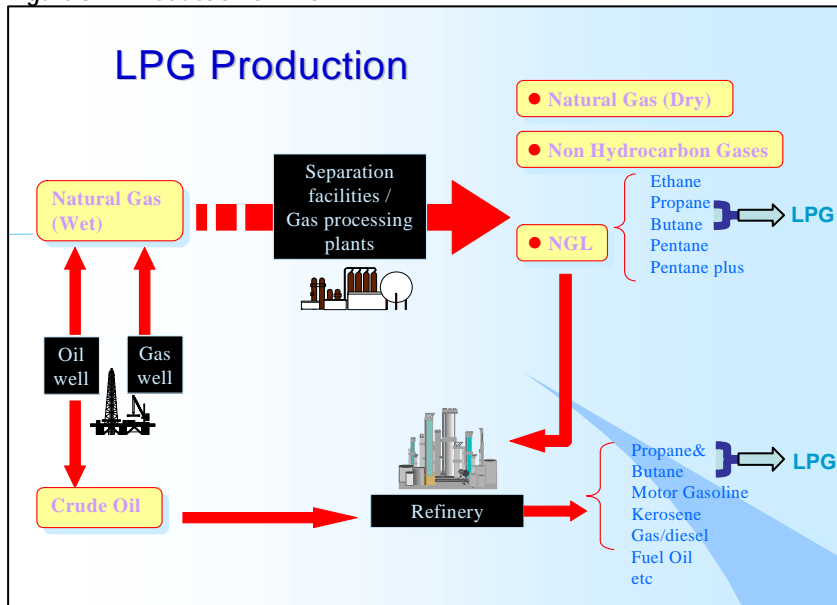

When crude oil and natural gas are produced from the well (either from associated or non-associated wells), they are a mixture of oil, water, sediment and dissolved gases (methane, ethane, propane, butane and pentanes). In the first instance, all gases are separated from the oil/gas mixture in **natural gas processing plants** and separation plants.

The gases are extracted because of their higher value and their readily marketable state, such as propane and butane which are Liquefied Petroleum Gases (LPG). In a later stage, the sediment and other unwanted substances are removed in treatment plants.

The gases are separated in a wellhead separation plant from onshore and offshore wells respectively. This happens through a separator on the platform. The methane will form the constituent of natural gas, while the others form the **Natural Gas Liquids (NGL)**. Natural gas liquids however, can also be produced in conjunction with natural gas.

Large amounts of LPG are also produced in **petroleum refineries** where they are separated from crude oil in the distillation process.

The different definitions used by the six international organisations: [LPG]

APEC, Eurostat and IEA: LPG is light saturated paraffinic hydrocarbons derived from the refinery processes, crude oil stabilization and natural gas processing plants. It consists mainly of propane (C₃H₈) and butane (C₄H₁₀) or a combination of the two. It is normally liquefied under pressure for transportation and storage.

OLADE: LPG consists of a mixture of light hydrocarbons which are obtained from petroleum distillation and/or natural gas treatment. The following three types are identified:

- a mixture of hydrocarbons of the C3 group (propane, propene, propylene);
- a mixture of hydrocarbons of the C4 group (butane, butene, butylene); and
- a mixture of C3 and C4 in any proportions.

OPEC: LPG is a light hydrocarbons fraction of the paraffin series produced in refineries and gas plants, comprising propane (C₃H₈) and butane (C₄H₁₀) or a mixture of these two hydrocarbons.

UNSD: Liquefied petroleum gas (LPG) – Hydrocarbons which are gaseous under conditions of normal temperature and pressure but are liquefied by compression or cooling to facilitate storage, handling and transportation. They are

- extracted by stripping of natural gas at crude petroleum and natural gas sources;
- extracted by stripping of imported natural gas in installations of the importing country; and

Product Definitions

- produced both in refineries and outside of refineries in the course of processing crude petroleum or its derivatives. It is generally made up of propane (C₃H₈) or butane (C₄H₁₀), or a combination of the two. Also included is ethane (C₂H₆) from petroleum refineries or natural gas producers' separation and stabilization plants.

Only UNSD includes ethane under LPG. For all other organisations, LPG comprises merely propane and butane. Volumes of LPG reported in all flows of the JODI questionnaire include LPG from gas plants except for the flow of refinery output.

3.3 Gasoline

Comprises motor gasoline and aviation gasoline

Motor gasoline is the principal fuel used in the transport/road sector and accounts for some 25% of total oil use in the world. In some countries, for example in the US, motor gasoline consumption is almost half of total oil consumption.

Motor gasoline is a complex mixture of relatively volatile hydrocarbons used for spark-ignition internal combustion engines. Gasoline is produced in refineries as the result of primary distillation of crude oil and then further processing, including changing the molecular structure, until the required specifications are met. The characteristics of the gasoline produced depend on the type of crude oil that is used and the setup of the refinery at which it is produced.

Motor gasoline may include some quantities of additives and blending components to improve fuel properties such as e.g. octane number, stability and deposit formation in engines.

Gasoline characteristics are also impacted by other ingredients that may be blended into it, such as ethanol. The performance of the gasoline must meet industry standards and environmental regulations that may depend on location.

The JODI definition of gasoline also includes **aviation gasoline** which is used in aviation piston engines. Aviation gasoline is a mixture of many different hydrocarbon compounds. The specification requirements for aviation gasoline, especially anti-knock, volatility, fluidity, stability, corrosiveness, and cleanliness impose severe limitations on the compounds that can be used.

The different definitions used by the six international organisations:

APEC, Eurostat and IEA: *Motor gasoline* consists of a mixture of light hydrocarbons distilling between 35°C and 215°C. It is used as a fuel for land-based spark ignition engines. Motor gasoline may include additives, oxygenates and octane enhancers, including lead compounds such as TEL (Tetraethyl lead) and TML (tetra methyl lead).

Aviation Gasoline: This is motor spirit prepared especially for aviation piston engines, with an octane number suited to the engine, a freezing point of -60°C and a distillation range usually within the limits of 30°C and 180°C.

OLADE: Gasoline/Alcohol: A mixture of light liquid hydrocarbons obtained from petroleum distillation and/or natural gas treatment, within boiling point range of 30°C to 200°C. It also includes alcohol obtained in distilleries and used as a fuel. This group includes:

Aviation gasoline: This is a mixture of reformed high-octane naphthas, which is very volatile and stable, with a low freezing point, used in propeller aircraft with piston engines.

Motor gasoline: This is a complex mixture of relatively volatile hydrocarbons, which with or without additives (such as lead tetraethyl), is used as fuel by internal combustion engines.

Natural gasoline: This is a product from natural gas processing. It is used as a raw material for industrial processes (petrochemicals), in refineries, or it is directly mixed with naphthas.

Alcohol: This includes both ethanol (ethyl alcohol) and methanol (methyl alcohol) used as fuels.

Ethanol is a colourless liquid that may be produced by the fermentation of plant materials with high sugar content, such as sugar-cane syrup or molasses; plant materials with high starch content, such as cassava, corn, etc; and materials with high cellulose content, such as firewood and plant wastes. It may be used in its anhydrous or hydrated state, alone or mixed with gasoline in internal combustion engines.

Methanol is also a colourless liquid that may be produced on the basis of a variety of raw materials, e.g. wood, plant wastes, methane, natural gas, coal. It is used in internal combustion engines.

OPEC: A complex mixture of relative volatile hydrocarbons, with or without small quantities of additives that have been blended to form a fuel suitable for use in internal combustion engines; includes gasoline used in aviation.

UNSD: Gasoline comprises motor gasoline, natural gasoline and aviation gasoline.

Motor gasoline – Light hydrocarbon oil for use in internal combustion engines such as motor vehicles, excluding aircraft. It distills between 35°C and 200°C, and is treated to reach a sufficiently high octane number of generally between 80 and 100 RON. Treatment may be by reforming, blending with an aromatic fraction, or the addition of benzole or other additives (such as tetraethyl lead).

Natural gasoline - Light spirit extracted from wet natural gas, often in association with crude petroleum. It is used as a petroleum refinery and petrochemical plant input and is also used directly for blending with motor spirit without further processing.

Aviation gasoline – Motor spirit prepared especially for aviation piston engines, with an octane number varying from 80 to 145 RON and a freezing point of -60°C.

For APEC, Eurostat, IEA and OPEC, gasoline comprises aviation gasoline and motor gasoline (including blending components such as bioethanol) – natural gasoline is classified under NGLs. The UNSD definition includes likewise motor and aviation gasoline but also natural gasoline. For OLADE gasoline comprises aviation gasoline, motor gasoline, natural gasoline and alcohol (ethanol/methanol) used as fuel.

3.4 Kerosene

Comprises jet kerosene and other kerosene

Jet kerosene is an aviation fuel. The aviation fuels include three types: aviation gasoline (see above Gasoline), gasoline (or naphtha) type jet fuel and kerosene type jet fuel.

In terms of demand for the different products, jet kerosene has a share of 99 % of all aviation fuels and it is the only one basic type of jet fuel in civil use world-wide. The wide-cut gasoline type of jet fuel has not been used by civil aircraft for many years (less than 0.05% of world aviation fuel demand) and, once the fuel for many military organisations, its military use has rapidly decreased over the last few years. Aviation gasoline (included in gasoline) accounts for slightly less than 1% of world aviation fuel demand.

Jet kerosene is a middle-distillate fuel, generally produced to exact the stringent specifications of international civil specifications, for use as civil aviation fuel. In recent years however, many military organisations, including for example NATO and SEATO, now use fuels which are virtually identical to some of the internationally accepted jet kerosene, mainly differing in the additives included.

Lower quality specification kerosene (**other kerosene**) or a dual purpose grade is used in some regions as domestic heating oil, especially in Asia, notably in Japan and Korea.

Please note that some organisations collect information for jet fuel. Jet fuel includes both kerosene type and naphtha or gasoline type jet fuel. This is not a substantial problem as the latter category barely represents 0.05% of world-wide aviation fuel demand.

The different definitions used by the six international organisations:

APEC, Eurostat and IEA: *Kerosene type Jet Fuel:* This is a distillate used for aviation turbine power units. It has the same distillation characteristics (between 150°C and 300°C, and generally not above 250°C) and flash point as kerosene. In addition, it has particular specifications (such as freezing point) which are established by the International Air Transport Association (IATA).

Other Kerosene: Kerosene comprises refined petroleum distillate and is used in sectors other than aircraft transport. It distills between 150°C and 300°C.

OLADE: *Kerosene and turbo: Kerosene:* A liquid fuel made up of the oil fraction that is distilled between 150 and 300 degrees Celsius. It is used as a fuel for cooking food,

lighting, in motors, in refrigeration equipment, and as a solvent for domestic waxes and insecticides.

Turbo fuel. This is kerosene with a special degree of refining, with a freezing point below that of common kerosene. It is used in reaction motors and turbo propellers.

OPEC: Comprises Jet fuel and Other Kerosene. **Jet Fuel:** Fuel of naphtha and kerosene type suitable for commercial or military purpose on aircraft turbine engines. **Other Kerosene:** Light hydrocarbon distillates in the 150 to 280°C distillation range and used as a heating fuel and as fuel for certain types of internal combustion engines.

UNSD: Kerosene-type jet fuel – Medium oil for use in aviation gas-turbine engines with the same distillation characteristics and flash point as kerosene, with a maximum aromatic content of 20% in volume. It is treated to give a kinematic viscosity of less than 15 cSt at -34°C and a freezing point below -50°C.

Kerosene – Medium oil distilling between 150°C and 300°C; at least 65% of volume distills at 250°C. Its specific gravity is roughly 0.80 and its flash point is above 38°C. It is used as an illuminant and as a fuel in certain types of spark-ignition engines, such as those used for agricultural tractors and stationary engines. Other names for this product are burning oil; vaporizing oil, power kerosene and illuminating oil.

Kerosene comprises of kerosene type jet fuel and other kerosene for all organisations.

3.5 Gas/Diesel Oil

For automotive and other purposes

Gas/diesel oil is a lighter fuel oil distilled off during the refining process and used primarily for heating, automotive purposes in diesel engines and for power generation.

Two main types are distinguished by their uses:

Transport diesel: Fuel used for internal combustion in on-road diesel engines, cars and trucks etc., usually of low sulphur content.

Heating Oil and Other Gasoil: This is a distillate fuel oil used mainly in stationary or marine diesel engines. It includes light heating oil which is used for residential or commercial space heating, or in industrial plants. It also includes marine diesel which is used for barge and boat engines and other heavier gas oils which may be used as petrochemical feed stocks.

Include also all gas/diesel oil which is used as international marine bunker fuel.

The different definitions used by the six international organisations:

APEC, Eurostat and IEA: Gas/diesel oil is primarily a medium distillate distilling between 180°C and 380°C. Several grades are available depending on use:

- Transport Diesel: On road diesel oil for diesel compression ignition (cars, trucks etc.), usually of low sulphur content;
- Heating and other Gas oil:
 - Light heating oil for industrial and commercial uses;
 - Marine diesel and diesel used in rail traffic;
 - Other gas oil including heavy gas oils which distil between 380°C and 540°C and which are used as petrochemical feed stocks.

OLADE: Liquid fuels obtained from atmospheric distillation of petroleum between 200°C and 380°C. It is heavier than kerosene and used in diesel and other compression-ignition engines.

Diesel Oil: Under this term, you can find the following products:

- Industrial diesel oil.
- Marine diesel for ships.
- Diesel oil for road motor vehicles.
- Gas oil which is a topping or catalytic cracking cut that some countries import or export to achieve a better balance for their refineries.

Product Definitions

In some countries industrial or marine diesel is called *gas oil*. This term can also be applied to a fuel that is slightly lighter than diesel oil, suitable for use in tractors and agricultural machinery.

OPEC: Gas/diesel oil refers to heavy oils obtained from atmospheric distillation or vacuum redistillation. The viscosity does not exceed 115" Redwood 1 at 38°C.

UNSD: Gas-diesel oil (distillate fuel oil) – Heavy oils distilling between 200°C and 380°C, but distilling less than 65% in volume at 250°C, including losses, and 85% or more at 350°C. Its flash point is always above 50°C and its specific gravity is higher than 0.82. Heavy oils obtained by blending are grouped together with gas oils on the condition that their kinematic viscosity does not exceed 27.5 cSt at 38°C. Also included are middle distillates intended for the petrochemical industry. Gas-diesel oils are used as fuel for internal combustion in diesel engines, as burner fuel in heating installations, such as furnaces, and for enriching water gas to increase its luminosity. Other names for this product are diesel fuel, diesel oil and gas oil.

All organisations include diesel used for transport as well as heating oil and other gas oil.

3.6 Heavy Fuel Oil

Heavy residual oil / boiler oil, including bunker oil

Heavy fuel oil is a blended product based on the residues from various refinery, distillation and cracking processes. It is a viscous liquid with a characteristic odour and it requires heating for storage and combustion.

Heavy fuel oil is used in medium to large industrial plants, marine applications and power stations in combustion equipment such as boilers, furnaces and diesel engines.

Heavy fuel oil is a general term and other names commonly used to describe this range of products include: residual fuel oil, bunker fuel, bunker C, fuel oil No. 6, industrial fuel oil, marine fuel oil and black oil. Moreover, terms such as heavy fuel oil, medium fuel oil and light fuel oil are used to describe products for industrial applications to give a general indication of the viscosity and density of the product.

Two main categories of fuel oil can be distinguished according to their sulphur content:

- Low sulphur fuel oil: sulphur content is lower than 1%
- High sulphur fuel oil: sulphur content is 1% or higher.

The different definitions used by the six international organisations:

APEC, Eurostat and IEA: This covers all residual (heavy) fuel oils (including those obtained by blending). Kinematic viscosity is above 10 C St at 80°C. The flash point is always above 50°C and density is always more than 0.90 kg/l.

- **Low sulphur content:** Heavy fuel oil with sulphur content lower than 1%.
- **High sulphur content:** Heavy fuel oil with sulphur content of 1% or higher.

OLADE: This is waste from refining oil, which includes all heavy products and is generally used in boilers, power plants and navigation.

Fuel Oil: Under this term, various products can be exported or imported. They include among others:

- Industrial fuel oil
- Marine fuel oil for ships
- Heavy fuel oil
- Reduced topping crude oil

OPEC: Fuel oil is heavier oils that remain after the distillate fuel oils and lighter hydrocarbons are boiled off in refinery operations. The viscosity is above 115" Redwood 1 at 38°C. It is used for the production of electric power, space heating, vessel bunkering, and various industrial purposes.

UNSD: Heavy oil that makes up the distillation residue. It comprises all fuels (including those obtained by blending) with a kinematic viscosity above 27.5 cSt at 38°C. Its flash point is always above 50°C and its specific gravity is higher than 0.90. It is commonly used by ships and industrial large-scale heating installations as fuel in furnaces or boilers.

Definitions given are generally comparable and uniformly refer to a high kinematic viscosity, flash point and density of this product. APEC, Eurostat and IEA differentiate additionally according to the sulphur content of this product, whereas OLADE, OPEC and UNSD differentiate in relation to its use.

3.7 Total Oil Products*

Categories (2) to (6) and all other petroleum products: refinery gas, ethane, naphtha, gasoline type jet fuel, petroleum coke, white spirit & SBP, paraffin waxes, bitumen, lubricants and others). Demand for Total Oil includes crude oil.

In order to simplify the JODI questionnaire, only specific data for the five main products are reported. However, to obtain a full picture, it is essential to know the volume of total oil produced, traded and delivered to the market.

Total oil includes all oil products: the five main product groups described above (LPG, Gasoline, Kerosene, Gas/diesel Oil and Heavy Fuel Oil) but also all the products which were not identified separately : refinery gas, ethane, naphtha, gasoline type jet fuel, petroleum coke, white spirit & SBP, paraffin waxes, bitumen, lubricants and other products.

*For the flow Demand, please also include the direct use of crude oil. This is for example crude oil used for power generation.

The definition of Total Oil Products should include all the other oil products not included in the major product categories. Care however should be taken not to double count certain products. For example: as ethane is already included under LPG for UNSD, it should not be separately added again in Total Oil Products.

Furthermore if additives and oxygenates (e.g. ethanol or bio-fuels) are included with gasoline (APEC, Eurostat/IEA and OLADE) then these products do not have to be added again to the Total Oil Products category. This is similar to the treatment of natural gasoline, if it was already accounted for under gasoline.

However, as specified above, crude oil for direct use should be added to the Total Oil Product category.

Finally in refinery output, all organisations exclude secondary products, except APEC, OPEC and OLADE, i.e. Naphtha from other products. For APEC, Naphtha is excluded only when it is re-processed into a new finished product. The amount of Naphtha that is delivered to final consumers is included in "Others".

4. Flow Definitions

4.1 Production (Crude Oil)

Marketed production, after removal of impurities but including quantities consumed by the producer in the production process

Crude oil production

In the JODI questionnaire, production only applies to crude oil. Production of refinery products is refinery output (see 4.6 Refinery Output).

Production is the removal of oil from the field, whether through primary or secondary recovery. Although this concept sounds simple, there are many different items that can be included or excluded when reporting crude oil production. The main differences however are between wellhead production and marketed production.

Wellhead production is all oil which exits the ground (wellhead). When the crude oil has been brought to the surface, it requires further treatment so that it can be sent to refineries for processing. The oil produced at the well-head varies considerably from field to field, due not only to the physical characteristics, but also to the amount of gas and water which it contains. Before the oil can be sold, the remaining gas, water and other impurities need to be removed. Once this is done, the oil is stored at the terminal before transport to refineries. It is at this point that the produced oil becomes *marketable (production)*.

Figure 4.1: Wellhead versus Marketed Production

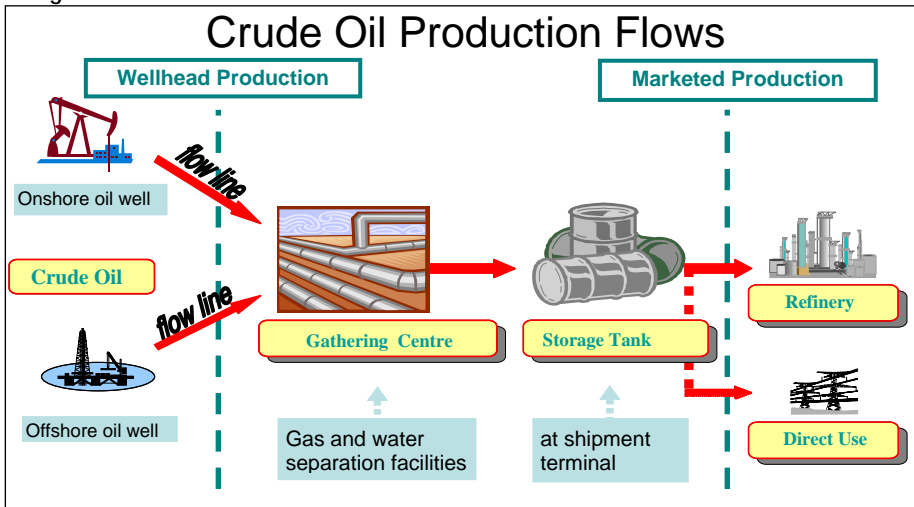

The different definitions used by the six international organisations: [Production (Crude Oil)]

APEC, Eurostat and IEA: Production within national boundaries including off-shore production. Production should only include marketable production, excluding volumes returned to formation. Such production should include all crude oil, NGL, condensates and oil from shale and tar sands, etc. It should also include the receipts of additives/oxygenates by refineries and blending plants from outside the refinery sector.

OLADE: Primary Energy Production: All energy extracted, exploited, harvested, etc., is considered to be of importance to country as evidently, it has been produced within the national territory.

Secondary Energy Production: Refers to the amount of energy that is generated from primary energy processing and/or in transformation centers, within the country, before accounting for self-consumption. If any part of the production is recycled to the same transformation center that it comes from, this should be deducted from production.

OPEC: Production volumes reported as crude oil include total crude oil coming out of degassing or treatment plants directly received or measured at storage facilities including shares from joint fields.

UNSD: Production refers to the quantities of fuel extracted, calculated after any operation for removal of inert matter contained in fuels. In general, it includes the quantities consumed in this process as well as supplies to other producers of energy or transformation or other uses. For crude petroleum, production is meant at the wells; for refined petroleum products to gross refinery output.

The term production is defined differently by the 6 organisations according to either more general or more specific energy or fuel reporting. APEC, Eurostat and IEA, use the term for all liquid production i.e. crude oil, NGL's, condensates and oil from shale and tar sands as well as additives/ oxygenates. The definition of production in OLADE is used for all energy production, for UNSD it is used for all energy as well as more specifically for crude oil and refined products, while OPEC's definition is only related to crude oil production excluding NGLs and condensates, if they can be separated in the commercial crude oil stream. In the JODI questionnaire the term production applies only to crude oil.

4.2 Imports and Exports

Goods having physically crossed the national boundaries, excluding transit trade. Exports should exclude international marine and aviation bunkers.

The trading of oil (both crude oil and oil products) raises a number of issues for reporting statistics of imports and exports.

- the concept of national territory
- the notion of customs clearance
- transit trade
- international marine and aviation bunkers

Both imports and exports should reflect amounts of oil having **crossed the national territorial boundaries**. It is therefore essential that there is a clear definition of what the statistical national boundary of the country is: E.g. - are some distant territories to be included in the statistical trade reporting or not?

Trade figures should report **physical flows** of oil and oil products. To that extent, customs clearance which sometimes is delivered long after the goods have crossed the national frontier should not be taken as the point of registering the import.

The trade figures however, are often derived from customs statistics, which take the customs clearance as the indicator for import or export. In the absence of other trade reporting systems customs statistics should be used.

Imports of crude oil and petroleum products, in order to be consistent with major economic indicators, should be, at least partly for domestic use. This implies that quantities passing through a country **“in transit” should not be included** in the import and export figures. Please note that if crude oil is imported to be refined in the country, and the products resulting from this process are exported (processing agreement), this is not considered as transit trade. Therefore, the quantities of crude oil imported for this purpose should be reported as an import and the resulting products which will be sold to another country should be reported as an export.

Deliveries of oil to ships for consumption during international voyages (**international marine bunkers**) or aviation fuels delivered for international flights (**international aviation bunkers**) should not be included in the export figures. International bunkers are fuels which are delivered to vessels or aircraft, irrespective of the country of registration, which are undertaking international voyages. The oil delivered as bunkers is to be used as fuel by the ship or aircraft and not as part of the cargo.

Although the fuels delivered for these purposes will be leaving the national boundaries of the country, they should **not be reported as exports**. For the purpose of the JODI questionnaire, the international marine and aviation bunkers are to be included in the demand figures. The reason for this is that in the JODI questionnaire, we try to monitor the total demand for oil including refinery fuel and bunkers (see below, under Section on Demand).

The different definitions used by the six international organisations: [Imports and Exports]

APEC: Imports and exports: Report the quantity of fuels obtained from or supplied to other countries. Amounts are considered as imported or exported when they have crossed political boundary of the country, whether customs clearance has taken place or not. The amount of fuels in transit (that is, on route through the country) should not be included.

Eurostat/IEA: Data should reflect amounts having crossed the national territorial boundaries, whether customs clearance has taken place or not. Quantities of crude oil and products imported or exported under processing agreements (i.e. refining on account) should be included.

Crude oil and NGL's should be reported as coming from the country of ultimate origin; refinery feedstock and finished products should be reported as coming from the country of last consignment. Any gas liquids (e.g. LPG) extracted during the regasification of imported liquefied natural gas should be included as imports in this questionnaire.

Petroleum products imported or exported directly by the petrochemical industry should be included. Re-exports of oil imported for processing within bonded areas should be included as an export of product from the processing country to the final destination.

Note: Imports or exports of ethanol (reported under Additives/Oxygenate) should relate to the quantities destined for fuel use.

OLADE: Import: Includes all primary and secondary energy sources originating from outside the borders and entering the country to make up a part of the total energy supply system.

Export: The amount of primary and secondary energy that a country allots to foreign trade.

Note: Some countries follow the practice of considering the aviation gasoline and retrofuel sold to foreign aircraft, as well as the bunker sold to foreign ships as exports. OLADE does not recommend this procedure, because in order to be consistent, it would have to record what domestic ships and craft load abroad as imports.

According to OLADE's conception, the amount purchased by a consumer within a country is assumed to be part of final consumption although the physical process of consumption may take place in international spaces or waters. The same occurs when a vehicle loads gasoline in one country and then crosses the border and consumes it in a

neighbouring country.

OPEC: Imports and exports comprise amounts having crossed the national territorial boundaries of the country whether or not customs clearance has taken place. Quantities of crude oil and oil products imported or exported under processing agreements (i.e. refining on account) are included. Quantities of oil in transit are excluded.

Crude oil and NGLs are reported as coming from the country of origin; refinery feedstocks and oil products are reported as coming from the country of last consignment. Re-export of oil imported for processing within bonded areas are shown as an export of product from the processing country to the final destination.

UNSD: Import and export refer to the amount of primary and derived energy obtained from, or supplied to, other countries (physically crossing the national borders but excluding transit shipments). Imports and exports of crude petroleum also include imports and exports of feedstocks, unrefined and semi-refined oils and components derived from crude petroleum. Fuels used in transit are excluded from imports and exports and are included under bunkers.

Trade definitions are common to all organisations, and emphasize the crossing of national territory whether or not customs clearance has taken place and the exclusion of oil in transit quantities. Crude oil and NGLs are reported as coming from the country of ultimate origin. Refinery feedstocks and finished products are reported as coming from the country of last consignment. International bunkers are excluded from exports and are reported in oil demand.

4.3 Closing Stocks

Represents the primary stock level at the end of the month within national territories; includes stocks held by importers, refiners, stock holding organisations and governments

Oil stocks are a critical element of information in an oil balance. The majority of oil stocks are essential to keep the global supply system operating. They are oil in pipelines going from the wellhead production sites to refineries, from refineries to consumers. Stocks are also held in tankers, railcars and road tankers linking production sites, refineries and consumers.

Not to include stock data in oil balance leads to a lack of transparency in the market. The trend in stocks is important for many oil analysts when making an evaluation of the oil market situation.

Stocks are a leading indicator of price movements: the level of oil stocks often determines the price, e.g. when oil stocks are low, it means that there may be a shortage or a need for replenishing, which indicates that prices will be rising. On the other hand, if the industry is amply supplied with the right oil, there may be a price reduction expected. This is why it is important to have information on the situation of oil stocks in the world.

Information on product stocks can be as important as crude oil stocks. For example, crude oil stocks give an indication of the availability of crude to refineries in each country, and therefore, are evidence of how well the refineries might provide the domestic market. On the other hand, information on low gasoline stocks before the driving season, or low heating oil stocks before the winter can be a warning signal to refineries, oil companies and governments that shortages might possibly occur – e.g. heating oil problems experienced in autumn of 2000.

Another relevant point is that data on oil stocks can be particularly important for strategic decisions, made by governments or larger oil companies. They need aggregate and timely stock information in order to look at their longer term planning, to ensure adequate supplies to meet projected demand. Governments also require extensive stock information so that they can react appropriately when oil supply disruptions occur (both national and international).

4.3.1 What are primary, secondary and tertiary stocks?

Please note that when referring to stock data, the terms primary and secondary are often used in a different context from when talking about primary and secondary products as commodities in an energy balance.

Primary stocks are held by the various companies supplying the market, ranging from producers, refiners to importers. They are held in refinery tanks, bulk terminals, pipeline tankage, barges and coastal tankers (if they stay in the same country), tankers in port (if they are to be discharged at port) and in inland ship bunkers. Additionally, stocks held for strategic purposes by governments (e.g. US SPR) or by stockholding organisations (e.g. EBV in Germany) are included in the primary stock category.

Secondary stocks are stocks in small bulk plants (marketing facilities below a certain capacity e.g. 50,000 bl in US, which receive their product by rail or truck) and retail establishments.

Tertiary stocks are stocks held by final end-consumers, they can be power plants, industrial entities or consumers in the residential/commercial sector.

4.3.2 What data should be collected?

Only data on primary oil stocks (both crude oil and products) should be reported in the JODI questionnaire, for several reasons:

- The **most important data** on stocks are primary oil stocks. These are stocks held by producers, refiners, importers, stock holding organisations and strategic stocks. The oil in pipelines or in rail tank cars, in road tank wagons etc which are necessary to keep the supply system operational are of lesser interest – they cannot be used as otherwise, the supply system would break down.

- Data on primary oil stocks is the **easiest to collect**. Data for secondary and tertiary stocks are rarely collected, as they are very difficult to obtain. The reason for this is that there are often too many retail stations, or small bulk plants in the country, and certainly, the number of end-users from which data would need to be collected is enormous. However, despite the lack of information, secondary and tertiary stocks can be very important, as they sometimes undergo large fluctuations, e.g. household heating oil tanks are rapidly depleted when weather is cold; retail stations stocks can be considerably run down when a tax increase is expected. Please note that terminology can differ in some countries, where no distinction is made between secondary and tertiary stocks and both categories are aggregated into secondary stocks.

Flow Definitions

- Information on primary oil stocks is consistent with the definition of "consumption" or to be more precise, "sales", which includes only sales or deliveries made by refineries and importers (i.e. primary suppliers), secondary and tertiary stocks should not be included.

- Primary oil stocks also represent stores of oil at a more centralised point in the supply chain, where it is feasible for them to be redirected. This is particularly important for oil importing countries during supply disruptions, as they need to know the potential volume of oil available to them. An example of these stocks is oil held at terminals, or in partly loaded tankers.

The following table lists the main categories to be included or excluded under Primary Oil Stocks (both crude oil and products):

<i>What should be included? *</i>	<i>What should not be included?</i>
<ul style="list-style-type: none">✓ Oil held at production facilities e.g. stocks on platforms or in partly loaded tankers moored at platforms✓ Stocks held for strategic purposes owned by governments or stockholding organisations✓ Oil in refinery tanks,✓ In bulk terminals,✓ Pipeline tankage (buffer stocks at pipelines)✓ Barges and coastal tankers (when port of departure and destination are in the same country)✓ Tankers in port **✓ In inland ship bunkers	<ul style="list-style-type: none">✗ in pipelines✗ in rail tank cars✗ in truck tank cars,✗ in sea-going ships bunkers✗ in retail stores and service stations✗ in bunkers at sea✗ military stocks

** Please note that there is a distinction between oil stocks and reserves. Reserves of oil (oil not yet produced) are not included.*

*** Stocks held on board incoming ocean vessels in port or at mooring should be included irrespective of whether they have been cleared by customs or not. Exclude stocks on board vessels at high sea.*

4.3.3 Location of Stocks

Stocks are to be reported on a national territory basis: All oil held within a country geographically is to be reported, irrespective of the ownership of the oil. For example, oil held in the Netherlands ARA zone (Amsterdam - Rotterdam - Antwerp) for the benefit of German companies is to be included in the Netherlands report, not in the German oil stocks.

Whether the stocks are held onshore or offshore does not make a difference as long as they are held on the national territory.

4.3.4 Timing / Cut-off date

Stocks of crude oil and petroleum products are volumes in storage at a particular time. For oil stocks to be consistent data with other oil flows, a monthly basis is chosen. As an example, sales of oil products are reported on a monthly calendar basis. That is why it is important to also measure stocks on a monthly basis. Stocks are therefore, considered at the beginning, i.e. 1st day of the month (Opening stocks) and end of each month, i.e. on 28/29/30 or 31st of the month (Closing stocks).

The stock changes are calculated as Closing stocks minus Opening stocks. The opening stocks of each month should equal the closing stocks of the previous month. A positive number indicates that stocks have increased during the month. A negative number for stock change shows a stock decrease.

4.3.5 Confidentiality of Stocks Data

In most countries, stock data are publicly available. However, in a few countries, stocks are still considered confidential; they are regarded as either sensitive information or as valuable commercial information, upon which competitors may act.

Given the importance of knowledge of stock levels, both for national purposes, and for international market analysis, it is of crucial importance that data on oil stock levels and changes be reported for all countries.

There are several reasons why the stock data requested in the JODI should not be treated as confidential. Firstly, because the level of aggregation of stocks requested in this questionnaire is on a national level, which makes it difficult to consider it as sensitive or commercial information. There is no disaggregation by owner, i.e. Oil Company, refinery or distributor, nor is there a disaggregation by location site. In these cases, the risk of disclosure of any commercially sensitive information is small.

Secondly, the time lag between the reporting time and the time that the information would be made available is too long to make it strategic data, worthwhile for the market or competitors to react. The oil industry usually acts on more detailed up-to-date information, and the information on oil stocks collected on a national basis may not be considered by the traders as detailed enough or as up-to-date enough to act upon.

Thirdly, the ultimate goal of the Joint Oil Data Initiative is full transparency, which can only be achieved if data are submitted for all products and all flows, including stock changes and levels.

The different definitions used by the six international organisations: [Closing Stocks]

APEC, Eurostat and IEA: Total stocks on national territory: All stocks on national territory, including stocks held by governments, by major consumers or by stockholding organisations, stocks held on board incoming ocean vessels, stocks held in bonded areas and stocks held for others, whether under bilateral government agreement or not.

OLADE: *No definition available as closing/opening stock data is not collected by it*

OPEC: Stocks include all nationally owned crude oil, refined products and gas plant products held within and outside national boundaries (on shore as well as floating) held by importers, governments, national oil companies and major non-importing final consumers in the following facilities; bulk terminals, refinery tanks, pipeline tankage, barges and tankers.

UNSD: Data on **closing stocks** refer to stocks at producers, importers and/or industrial consumers at the end of the month. In some cases, however, stock series have been derived on the basis of the difference between gross availabilities for transformation or consumption and official or published data on actual consumption.

For all the organisations, the definition for stocks is defined "geographically" or "by territory" except for OPEC which is characterized by the "ownership".

4.4 Stock Changes

**Closing minus opening level.
A positive number corresponds to a stock build;
a negative number corresponds to a stock draw.**

As for stock levels, only changes in primary oil stocks of crude and products should be reported.

Stock changes are calculated as the closing stock level minus the opening stock level.

Opening stock level is the amount of primary stocks on national territory, measured on the first day of the month being reported (e.g. 1st June). **Closing stock** is the amount of primary stocks on national territory measured on the last day of the month being reported (e.g. 30th June).

Thus, a stock build is shown as a positive number, and a stock draw as a negative number.

Please note that in some other reporting systems, the stock changes are opening minus closing levels. A stock build is then shown as a negative number and a stock draw as a positive number.

There is no unanimity about which calculation to use. However, the international oil industry is in general using the JODI definition mentioned above.

The different definitions used by the six international organisations:

APEC, Eurostat, and IEA: Total stocks on national territory: Stock changes should reflect the difference between opening stock level and closing stock level for stocks held on national territory. A stock build is shown as a negative number, and a stock draw as a positive number. (Annual Questionnaire).

OLADE: Inventory variation is the difference between initial stocks (at January 1) minus final stocks (at December 31) for a given year, in the storage facilities for different products.

Inventory variation is considered according to its nature. Thus, an inventory increase means a reduction in the total supply and vice-versa.

Oil and Derivatives Inventory Variation

The location of storage tanks where inventory variations are caused and are mentioned below are valid for oil, liquefied gas, gasoline/alcohol, diesel oil, fuel oil, other secondary products, and non-energy sources.

- Ports that control import and export movements
- Oil producing reservoirs
- Refineries, where crude oil is transformed into derivatives
- Gas treatment centers, where condensables such as natural gasoline and liquefied gas are extracted from natural gas
- Power plants that use diesel oil and fuel oil as raw materials

OPEC: Stock changes reflect the difference between closing levels on the last day of the period and opening stock levels on the first day of the period of stocks on national territory held by producers, importers, energy transformation industries and large consumers. A stock build is shown as a positive number, and a stock draw as a negative number.

UNSD: Stock change refers to the difference between the amount of fuel in stock at the end and the beginning of the month. A positive stock change (+) reflects additions to stocks, which in effect, decreases "apparent consumption"; while a negative stock change (-) creates exactly the opposite result.

APEC, Eurostat, IEA and OLADE report stock build as negative and stock draw as positive. OPEC and UNSD report stock build as positive and stock draw as negative.

4.5 Refinery Intake

Observed refinery throughputs

In this flow, the quantities of crude oil inputs entering the refinery should be reported. Although there are several other inputs to refineries e.g. Natural Gas Liquids (NGL), refinery feedstocks, additives, biofuels and other hydrocarbons, currently the questionnaire is not collecting any details of any other inputs than crude oil.

Please also note that the volume of crude oil reported as refinery intake should reflect the real quantities of inputs to the refinery process and not the deliveries of crude oil to the refinery. The difference between the two measures is the stock changes of crude oil at the refinery.

See Figure 4.2 below for a chart of the main refinery flows.

The different definitions used by the six international organisations:

APEC, Eurostat and IEA: This is defined as the total amount of oil (including other hydrocarbons and additives) observed to have entered the refinery process.

OLADE: Amount of crude oil loaded in the primary distilling unit of refineries, from which flow intermediate currents that are processed in the conversion units. The main ones are:

- Reforming: increases the octanes of gasolines
- Cracking: increases both the octanes and yield of gasolines
- Hydrocracking: increases the yield of diesel and improves its cetane index
- Vacuum: distilling at a very low pressure to separate into two fractions the reduced crude oil from primary distilling
- Viscosity reducer: improves the viscosity of fuel oil
- Coking: increases the amount of gasoline beyond what cracking does, but as the octanes are very low, it requires reforming.
- Flexicoking: increases even more the yield of gasoline and liquefied gas
- Isomerization/polymerization: increases the octanes of gasolines beyond reformation and cracking, especially for aviation.

OPEC: Total input of crude, NGL, condensates and feedstocks to atmospheric crude distillation unit.

UNSD: Refinery input/intake is composed of the quantities inputted into the refinery process and of the portion of the output from refineries which is in the form of products that have no direct marketable use, but which can be "re-input" into the refinery process ("backflow").

Refinery Intake definitions are common to all organisations, comprising crude, NGL, condensates, feedstocks and additives.

4.6 Refinery Output

Gross output (including refinery fuel)

Refinery production

This is the production of finished petroleum products at a refining or blending plant. Production equals the Input into the refinery minus the Refinery Losses. Petroleum products from secondary products like Naphtha should not be included in refinery output.

The terms Net and Gross production are frequently used when referring to refinery output. *Gross production* comprises the amount of fuel which is used in the refinery in support of the operation of the refinery (refinery fuel). *Net refinery production* excludes the refinery fuel.

If for any reason, inter-product transfer cannot be separated from the refinery output data, data providers should indicate whether the inter-product transfers are included in the refinery production or not.

Figure 4.2: Main Refinery Flows

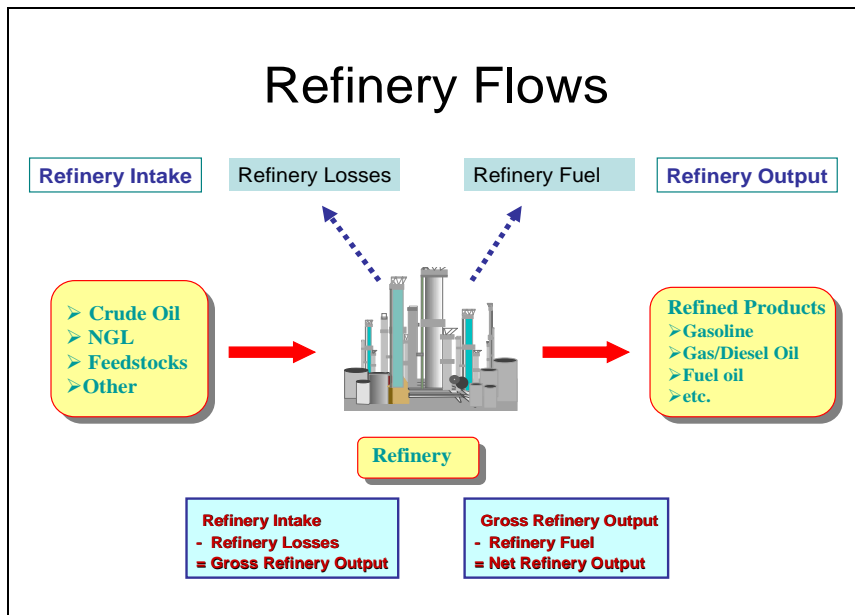

The different definitions used by the six international organisations: [Refinery Output]

APEC, Eurostat and IEA: *Gross Refinery Output*: This is production of finished products at a refinery or blending plant. This category excludes Refinery Losses, but includes Refinery Fuel. The total must be equal to Refinery Intake (Observed) minus Refinery Losses.

***Refinery Fuel*:** These are all petroleum products consumed in support of the *operation* of a refinery. This should not include products used by oil companies outside the refining process, e.g. bunkers or oil tankers.

OLADE: This description is valid for products such as gases, liquefied gas, gasoline/alcohol, kerosene, diesel oil, fuel oil, coke, other secondary products and non energy products in refineries.

For each product, the amount produced by all refineries, in the national territory, should be recorded. If any part of the products produced in one refinery is recycled in another, that amount should be subtracted from what will be considered production.

The primary products obtained from a refinery are:

- gases: refinery gas (C1–C2) and liquefied gas (C3–C4)
- light: motor gasoline, aviation gasoline, naphthas for petrochemistry, solvents
- medium: kerosene, jet fuel, gas oil, diesel oil
- heavy: fuel oil, asphalts, lubricants, greases, coke

OPEC: The total amount of petroleum products produced from refinery input in a given period, excluding refinery fuel and loss.

***Refinery Fuel and Loss*:** The total amount of finished or unfinished products used in refineries as fuel, or lost during refinery operation through spillage, evaporation and venting.

UNSD: Refinery output refers to the marketable end-products of the refinery process, excluding refinery losses but including the quantity of fuels consumed at refineries (refinery fuel used in the actual refining process and the fuels used for other ancillary purposes).

APEC, Eurostat, IEA and UNSD exclude refinery loss but include refinery fuel. OPEC excludes both. The OLADE definition does not mention anything about refinery fuel or loss. Inter-product transfers are excluded by all organisations except OPEC and OLADE.

4.7 Demand

**Deliveries or sales to the inland market
(domestic consumption)
plus Refinery Fuel
plus International Marine and Aviation Bunkers.
Demand for Total Oil includes Crude Oil**

The total demand of oil in a country includes the volume of oil required, on the one hand to supply all final consumers, energy transformation units (including refineries), energy producers within the country and on the other hand to provide all the national and foreign customers with fuels which they will use in international navigation and aviation (e.g. international aviation, marine bunkers, fishing etc.).

Total oil demand also includes volumes of crude oil, NGL and other hydrocarbons which are used directly without being processed in petroleum refineries (direct use). It concerns mainly oil which can be used unprocessed by power plants to generate electricity and heat.

Since in most oil balances the information for some of these flows is available, the equation looks as follows:

Figure 4.3: Demand Flows

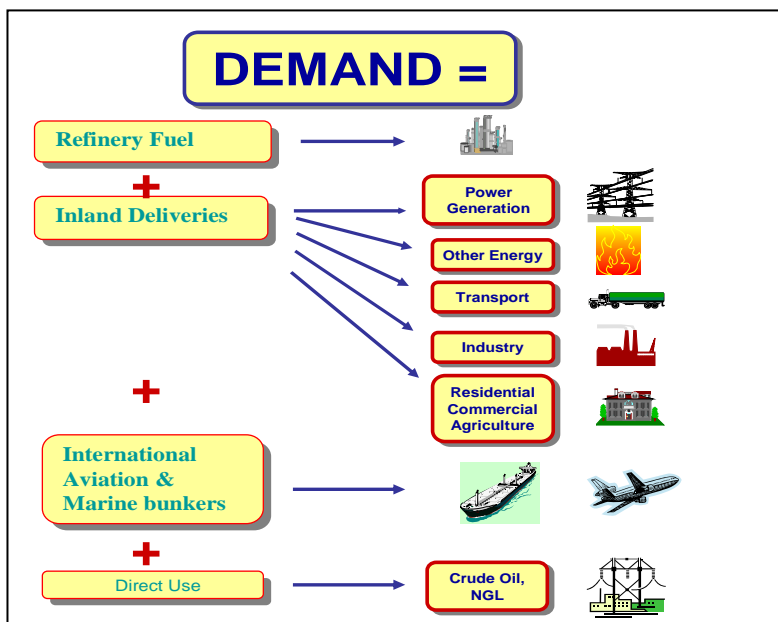

5. Verification of Data Quality

5.1 Data Quality Assessment

Data quality encompasses many aspects. For the data submitted in the JODI questionnaire, the following items have been taken into account when assessing a country's data quality.

- **Timeliness:** The JODI database is expected to be updated regularly. Timeliness indicates whether submissions were received by the expected deadline. Ratings over a six month period ranging from "good" to "less timely" are given according to the number of submissions received within the deadline.
- **Sustainability/Submission:** Sustainability refers to the number of the JODI submissions received within a given period. For example, if a country over a six month period has submitted all 6 questionnaires, then it is given a "good" rating, if fewer questionnaires were submitted, then lower ratings are given.
- **Completeness:** Completeness measures the number of expected data points out of the maximum 42 in the JODI questionnaire. A "good" rating is given when more than 90% of the data are provided for production, stock changes, closing stock levels and demand.
- **Accuracy:** Accuracy of JODI data for a country is much more difficult to measure, as there is often no real benchmark to measure against. Moreover, if data are accurate for one flow, e.g. production, it does not necessarily mean that all the other flows are accurately reported. It is thus, almost impossible to give a single rating concerning the data accuracy of an individual country.

To be able to establish some indication of data accuracy however, several verification methods can be used for evaluation of data, either by international organisations or by national administrations providing the data. The next chapter will be dealing with the type of measures national administrations can take to ensure data accuracy.

For more information and the latest update of countries' data quality, please also consult the website: www.jodidata.org

5.2 Focus on Data Accuracy

Accuracy is an essential quality of an ideal database. With it, users can be assured of the database's reliability and usability, which are paramount to statistical analysis.

As JODI was initiated in order to measure how quickly national administrations could provide accurate data on a monthly basis, timeliness and completeness became the focus of attention during the first years of the Initiative. However, now that a database is in place where information is stored, it is essential that accuracy be given the necessary attention that it deserves.

Initially the six participating organisations and the IEFIS had taken a decision that the database would only be released if it was proven to be of sufficient quality. An extended evaluation exercise was carried out during 2005; the results of which showed that quality, although not perfect, was satisfactory, especially for the top 30 producers and consumers. It was therefore, decided in November 2005 to open up the database to the public. In anticipation of criticism from some users, colour coding was added to indicate data confidence (See Chapter 8).

Now that the database is operational, it is imperative that accuracy continues to improve. Accuracy needs to be evaluated by both the international organisations to which countries submit their data and by the national administration submitting the data. International organisations each have their respective techniques to verify data accuracy and they do so on a regular basis, contacting national administrations in case of problems.

In order to facilitate the task of data accuracy evaluation by national administrations, this chapter provides a set of instructions and possible checks for verification of data accuracy from the standpoint of the national statisticians.

Some data accuracy verification techniques that can be applied to JODI submissions are as follows:

1. Balance Check
2. Internal Consistency Check
 - 2.1 Fuel Balance: Sum of Products versus Total Oil
 - 2.2 Stocks Check
3. Time Series Check
4. Visual Check

Please note that some of these checks only provide an indication of accuracy. It is important to use a combination of checks in order to obtain the best results.

5.2.1 Balance Check

$$\text{Calculated Supply} = \text{Production} + \text{Imports} - \text{Exports} - \text{Stock changes}$$

This is the simplest form of accuracy check. Herein, the statistician should check that the calculated supply is not very different to the reported demand. The calculated supply is equal to production plus imports minus exports plus or minus stock change. Mathematically, it is expressed in the above equation.

Production specified here could be either indigenous production of crude oil or local refinery production of petroleum products as defined in Chapter 3. Imports, exports and stock changes should also follow the definitions in Chapter 4.

The Calculated Supply using the above formula should not be very different from the reported refinery intake/demand. Ideally, the deviation should be between -5.0 and 5.0 percent. If the deviation is outside this range, the statistician should review the data for all the flows and make corrections where necessary. However, if after due verification, the deviation is still large, the data may be submitted to the respective organisations. If more accurate data are received in the following month, then a revised and corrected balance should be resubmitted the following month.

This data check is applicable only if data for the flows are complete and reliable. Moreover sometimes the deviation between Calculated Supply and the other flows is for some valid reason larger than -5% and +5%. This balance check can therefore only be considered as one of the possible checks which can be carried out to evaluate accuracy.

An example where the calculated supply is larger than 5% is, when Refinery Intake or Demand is lower than the Calculated Supply as shown in Table 5.1. There are several possible reasons for this. The statistician may suspect that the Refinery Intake and Demand may be underreported. But it would also be possible that the other flows are over-reported. Therefore, it would be plausible if all of the data are reviewed for accuracy.

Table 5.1: Example 1 of Internal Balance Check

Unit: 1,000 Metric Tons

		Crude Oil
Indigenous production	+	2
Imports	+	3681
Exports	-	0
<i>Stock Closing Level</i>		3474
Stock Change	-	-295
Refinery Intake		3750
Calculated Supply	=	3978
% Deviation with Reported Intake	%	6.1%

There may also be cases where the Calculated Supply is lower than the Refinery Intake or Demand by more than -5% (See Table 5.2).

As mentioned above, there may be justifications for differences between reported and calculated supply figures. Taking the example of gasoline, the difference in calculated supply was larger than -5% for a valid reason. Looking at a complete balance for gasoline (See Table 5.2), it becomes apparent that some 25 thousand tonnes of biofuels (e.g. ethanol) were blended with the gasoline. This flow (Primary Product Receipts) is not specifically requested in the JODI, and therefore not included in the balance as shown in the first part of the table, although the delivered gasoline demand data would include this. Several other flows (e.g. inter-product transfers, transfers, recycled products etc) are not specifically requested in the JODI balance, in order to keep reporting simple.

A careful review of the data is advised to minimize the deviation.

Table 5.2: Example 2 of Internal Balance Check (where deviation is justified)

Unit: 1,000 Metric Tons

		Gasoline
Refinery production	+	1083
Imports	+	15
Exports	-	555
<i>Stock Closing Level</i>		1065
Stock Change	-	101
Demand		482
Calculated Supply	=	442
% Deviation with Reported Demand	%	-8.3%

Example with Interproduct Transfers

		Gasoline
Primary Product Receipts*	+	25
Refinery production	+	1083
Imports	+	15
Exports	-	555
<i>Stock Closing Level</i>		1065
Stock Change	-	101
Demand		482
Calculated Supply	=	467
% Deviation with Reported Demand	%	-3.1%

* Ethanol blended with gasoline

5.2.2 Internal Consistency Check

5.2.2.1 Fuel Balance: Sum of Products versus Total Oil

$$\text{Total Oil} = \text{LPG} + \text{Gasoline} + \text{Kerosene} + \text{Gas/Diesel Oil} + \text{Fuel Oil}$$

Another measure of accuracy is consistency. The category Total Oil includes not only the sum of the reported products namely: LPG, Gasoline/Aviation Gasoline, Kerosene (including Jet Kerosene), Gas/Diesel Oil and Fuel Oil, but also some of the minor oil products such as refinery gas, ethane, naphtha, petroleum coke, white spirit & SBP, paraffin waxes, lubricants and other products. (See Chapter 3). It is thus logical that the sum of the five products enumerated in the JODI questionnaire should not be greater than Total Oil.

The statistician should ensure that this property holds. Should this not be the case, then a careful review and appropriate corrections of the data are necessary before submitting the data to their respective organisations.

Table 5.3: Example 1 of Fuel Balance Check

Unit: 1,000 Metric Tons

	LPG	Gasoline	Kerosene	Gas/ Diesel Oil	Fuel Oil	Total Oil	Subtotal*	Difference: Total Oil - Subtotal
Refinery Output	126	866	334	1083	942	2338	3351	-1013
Imports	59	0	0	0	60	121	119	2
Exports	13	208	143	555	26	1062	945	117
Stock closing Level	95	884	317	1065	1154	4026	3515	511
Stock Change	-2	-47	-10	101	-92	-90	-50	-40
Demand	176	700	201	482	1080	3558	2639	919

*Subtotal above is the sum of LPG + Gasoline + Kerosene + Gas/Diesel Oil + Fuel Oil

In Table 5.3, the column Sub-total is the sum of the five products, namely: LPG, Gasoline, Kerosene, Gas/Diesel Oil and Fuel Oil. The sub-totals for four of the five flows are less than the Total Oil which shows that for these flows, there is internal consistency. However, the sub-total for Refinery Output is larger than the corresponding Total Oil. There is therefore, an error in the data for that particular flow. This method does not apply to stock changes.

In a second step, the statistician can check the percentage of "Other Products" which are not shown separately. See Table 5.4.

Table 5.4: Example 2 of Fuel Balance Check

Unit: 1,000 Metric Tons

	LPG	Gasoline	Kerosene	Gas/ Diesel Oil	Fuel Oil	Total Oil	Subtotal*	Difference: Total Oil - Subtotal	% difference
Refinery Output	126	866	334	1083	942	3838	3351	487	13%
Imports	59	0	0	0	60	1021	119	902	88%
Exports	13	208	143	555	26	1062	945	117	11%
Stock closing Level	95	884	317	1065	1154	4026	3515	511	13%
Stock Change	-2	-47	-10	101	-92	-90	-50	-40	
Demand	176	700	201	482	1080	3558	2639	919	26%

*Subtotal above is the sum of LPG + Gasoline + Kerosene + Gas/Diesel Oil + Fuel Oil

From the above table, it is clear that although the sub-totals are all lower than Total Oil, there is still an error in the table. This can be established by calculating the percentage difference between the Subtotal and Total Oil. In the above case, it is highly unlikely that the Other Products would account for 88% of the Total Oil Imports, providing therefore an indication that there is an error in the reported data.

There is therefore a need for statisticians to check the values of all the products including Total Oil.

5.2.2.2 Stocks Check

$$\text{Stock Change} = \text{Closing Stock for M-1} - \text{Closing stock for M-2}$$

The difference between the closing stock level of the latest month (M-1) and the closing stock level of the previous month (M-2) should be equal to the reported stock change of the latest month. If for any reason this is not the case, the statistician should investigate and make the necessary correction. The difference between the reported stock change and calculated stock change should be 0. A reason for a deviation could stem from the stock change for M-1 being obtained using preliminary closing stock levels for M-2. If M-2 stock levels have since been revised, then a revision for the previous months should be submitted.

However, if this is not the case despite serious efforts to achieve a balance, the statistician could settle to a maximum deviation of not greater than 5.0 percent.

Table 5.5: Example of Checking Consistency of Stocks Data

Unit: 1,000 Metric Tons

	Crude Oil	LPG	Gasoline	Kerosene	Gas/Diesel Oil	Fuel Oil	Total Oil
Stock Closing Level							
M-1 (Jan)	1637	181	660	259	533	214	2685
M-2 (Dec)	1618	192	778	213	676	260	2880
Stock Change in M-1 (Jan)	19	-18	-118	54	-143	-48	-195
Calculated Stock Change (M-1 – M-2 or Jan – Dec)	19	-11	-118	46	-143	-46	-195
Difference (Calculated – Reported)	0	-7	0	8	0	-2	0
Percentage Difference (Difference/Stock Change)	0%	39%	0%	15%	0%	4%	0%

In Table 5.5, the Calculated Stock Change is computed using the above-mentioned formula. This Calculated Stock Change should be equal to the reported Stock Change. In the above example, the reported stock change for LPG, Kerosene and Fuel Oil are not equal to the Calculated Stock Change.

When calculating the percentage difference it is noticeable that for LPG and Kerosene the differences are larger than 5%, whereas for Fuel oil the difference is only 4%. Therefore the stock data for LPG and kerosene need investigating, while the fuel oil data seems within reasonable error limits.

5.2.3 Time series Check

$$\text{Percentage Change (\%)} = \frac{\text{Current Month Data} - \text{Previous Month Data}}{\text{Previous Month Data}} \times 100$$

This is another method that the statistician could use to check the accuracy of some of the flows, for example indigenous production, refinery production, closing stock levels or demand. The method is less useful for trade and stock changes. A time series check involves comparing the demand data of the latest month to that of the previous month and/or to the data of the same month in the previous year.

The underlying reason for checking monthly data with previous data is that the percentage change, in for example demand, is usually limited from one month to the next. The statistician should compute the monthly growth rates and use the past growth rates as an indication of the trend of the growth rate for the latest month. If demand in the previous seven months has been growing at 3%, then it is likely to expect a similar

growth this month. However this can only be considered as an indication, as many times there are logical reasons for larger than expected deviations.

In countries where there is a large seasonal pattern in demand, a comparison with the same amount of the previous year is more relevant.

Should the growth rate therefore exceed or go below the trend, the statistician should investigate. If the percentage change seems correct, then it is recommended that the statistician find the cause of such occurrence. If the reason is plausible, then the data might be accurate despite not going with the trend.

Table 5.6: Comparing Growth Rate for the Latest Month to the Historical Trend

Demand	Monthly Growth Rate (Previous 12 Months)			March
	Minimum	Maximum	Average	
LPG	-9.2%	11.1%	0.8%	15.0%
Gasoline	-10.1%	8.9%	0.0%	8.0%
Kerosene	-10.3%	8.1%	0.5%	-10.4%
Gas/Diesel Oil	-12.0%	9.4%	-0.6%	-3.0%
Fuel Oil	-25.3%	23.0%	1.0%	5.0%
Total Oil	-7.1%	7.3%	-0.5%	2.0%

In Table 5.6, the calculated growth rates for the demand in March using the above formula are compared with the maximum and minimum monthly growth rates during the previous 12 months or year. The growth rates of LPG and Kerosene for the month of March are higher than the maximum growth rates and lower than the minimum monthly growth rates observed in the previous 12-month period.

There is no certainty that such developments could not happen in the oil market, for example an exceptionally cold winter may make the demand for kerosene much higher than the previous year, or adversely an exceptionally mild winter may result in much lower demand. However, seeing growth rates which are much higher or lower than those seen in the last 12 months may provide an indication that data may need to be investigated.

5.2.4 Visual checks

An easy method to rapidly verify time series is to graphically represent the data series. By using this method, outliers, which are data points far from the rest of the data, can be easily detected. To be able to graphically show time series however, it is essential that the statistician has developed and maintained a database of historical data.

The method for visually checking time series can be used for most of the flows, although it is less easy to spot outlying data for stock changes, as these are fluctuating between positive and negative and can vary more than the other data.

An example is shown below of refinery intake data where two values are clearly out of the normal range. The low value of refinery intake (April 2005) could indeed be valid, as refineries might have closed down for refinery maintenance, however the high value in December 2005 seems out of line, as it is unlikely that refinery intake can have increased substantially for one month.

If such occurrences are visible, the statistician should investigate further to determine whether the value is valid or not.

Figure 5.1 Refinery Intake Volumes

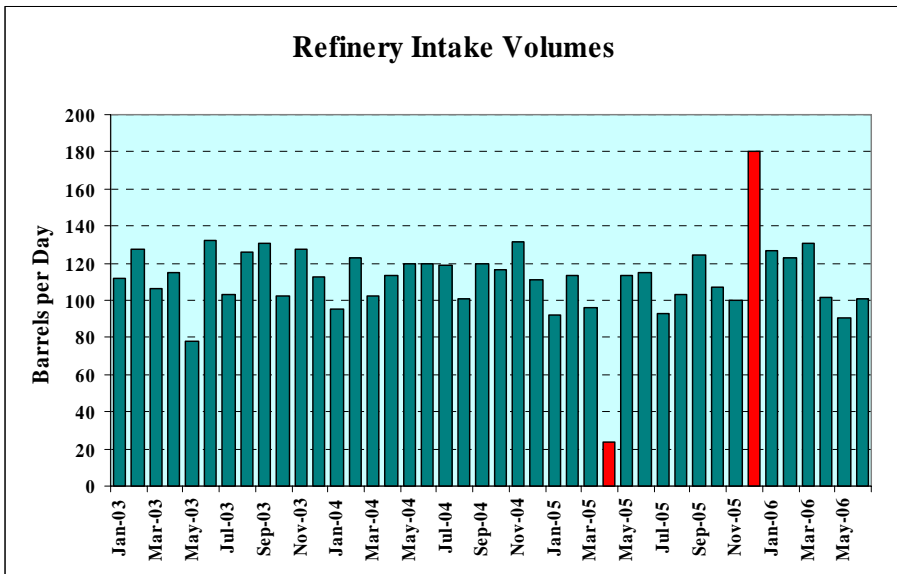

5.3 Monthly versus Annual Data

5.3.1 Monthly data

5.3.1.1 Data collection and coverage

Production and stock data are collected from oil companies every month.

Challenges/problems:

- Reporting period is short.
- Not all the data suppliers are able to send the data to the national institute responsible for the data collection/verification and dissemination (either the national statistical office or ministry of petroleum/energy/economy).

Trade data (export/import) is collected mainly from the customs offices.

Challenges/problems:

- Longer time lag for getting the trade data (in many developing countries).
- Consolidation of value and physical data.

Trade data, when they become available, can be considered as full coverage.

5.3.1.2 Estimates or full coverage data

In a case of missing data submission, the institute shall make estimates for the missing data and employ a monitoring system to check the consistency of the estimates between months. At the same time, efforts should be made at the institute to convince all the data suppliers of the importance of their participation in reporting the data.

The national institutes are expected to describe the estimation techniques applied and the checking criteria in the metadata.

5.3.1.3 Missing monthly data

National institute responsible for JODI is not sending data to the JODI team.

Problem:

- The JODI team decided not to make estimates for the countries, so the missing report will appear as 'empty' cells for the month in the JODI World Database.
- The missing data is hurting the comparability, completeness of the world database and in a way, inflating the work of many countries that do send the data to the JODI team.

5.3.2 Annual data

Annual data is, in principle, a simple aggregation of the twelve consecutive months. However, given the coverage described above, there could be the following cases observed:

5.3.2.1 Annual data is a simple sum of the 12 consecutive months of the year

National institute responsible for JODI collected the necessary data from all the data suppliers. Data was not revised in any of the 12 months of the year. In this case, the annual data is the sum of the 12 months' data registered in the JODI World Database.

5.3.2.2 Monthly data is to be re-consolidated in order to derive annual data from the monthly data

If national institute responsible for JODI made estimations for some of the months because of incomplete coverage than a consolidation of data is required, the consolidation will assure that the coverage and reliability of data is reasonable. Also, backward revision of the monthly data should be performed to assure the consistency of monthly and annual data.

The national institutes are expected to describe the estimation techniques and the consolidation criteria in the metadata.

5.4 Common Reporting Errors

Another way to improve data accuracy is by preventing common errors in data collection, processing and reporting. To ensure that these errors are avoided, a table is provided showing the most frequent “common errors” and a corresponding suggestion on how to avoid them:

Products and Flows	Common Errors	Suggested Preventive Measures
<i>Crude Oil Production</i>	<ol style="list-style-type: none"> 1. In some cases, the data include NGL 2. In some cases, the data exclude Lease Condensates 3. In some cases, wellhead production instead of marketable data are reported 4. Crude Oil production of foreign companies operating within the country are reported as imports 	<ol style="list-style-type: none"> 1. Ask data providers to report Crude Oil, Lease Condensate and NGL separately, if the data are available, so that the statistician can follow the JODI definition. 2. Same as 1. 3. Statisticians should ask upstream oil companies to report the marketable production. 4. Crude Oil production within the national boundaries of the country is indigenous production of that country, no matter the nationality of the producer.
<i>Refinery Intake</i>	Like in Crude Oil Production, refinery intake includes NGL and Refinery Feedstocks or excludes Lease Condensate	Ask data providers to report Crude Oil, Lease Condensate and NGL separately, if the data are available, so that the statistician can follow the JODI definition.
<i>Refinery Output</i>	<ol style="list-style-type: none"> 1. In some cases, LPG output from gas separation plants are reported as refinery output 2. In some cases, there is double counting of finished products produced from intermediate products 	<ol style="list-style-type: none"> 1. Report only the output of Oil Refineries. 2. Only production of finished oil products should be reported in refinery output. If some products are used for further processing to other products, then only the final output should be reported to avoid double counting. An example is naphtha, re-processed to produce other products. The re-processed naphtha should not be included as refinery output. Only the amount exported or delivered to final consumers should be reported.

Products and Flows	Common Errors	Suggested Preventive Measures
<i>Demand</i>	<ol style="list-style-type: none"> In some cases, Refinery Fuel and Aviation/Marine Bunkers are not included In some cases, only inland sales are reported. Refinery fuel and direct use of crude oil are not included in Total Oil. In some cases LPG from gas separation plants are not included 	<ol style="list-style-type: none"> Demand data should include Refinery Fuel and Aviation/Marine Bunkers and direct use of Crude Oil. Demand data should include Refinery Fuel and Aviation/Marine Bunkers and direct use of Crude Oil. Practically, it is difficult to trace the source of LPG. All LPG sold should be reported.
<i>Stocks Closing Levels</i>	<ol style="list-style-type: none"> In some cases, only industry or government stocks are included in the total and not the sum of both Some countries do not report stocks data due to confidentiality 	<ol style="list-style-type: none"> By definition, the total national territory stocks should be the sum of government and industry stocks. Data providers should be informed that individual stocks information will not be divulged. The national administration will only release the total stocks data.
<i>Stock Change</i>	<ol style="list-style-type: none"> In some cases, a stock build is submitted with a negative sign while a stock draw is shown with a positive sign In some cases, stock changes is estimated as the difference between supply and demand The difference in closing stock level of M-1 and M-2 is not equal to the reported stock change 	<ol style="list-style-type: none"> Stock change should be calculated as the difference between closing stocks – opening stocks, or of closing stocks (M-1) – closing (M-2) stocks. National administrations should collect data for both the closing stock levels and the stock changes. This may be true in some cases due to statistical discrepancy. In this regard, this difference should not be bigger than 5% or less than -5%.
<i>Gasoline</i>	<ol style="list-style-type: none"> In some cases, Aviation Gasoline and blending components are not included in the Gasoline data submitted In some cases, Alcohol production is included in the reported Gasoline production 	<ol style="list-style-type: none"> Please strictly follow JODI definition Only Gasoline production, with or without alcohol blend, should be reported. The amount of alcohol production, especially if it is not blended with gasoline, should not be included.
<i>Kerosene</i>	<ol style="list-style-type: none"> In some cases, the Kerosene data submitted do not include Jet Kerosene In some cases, Other Kerosene is included in Gas/Diesel Oil 	<ol style="list-style-type: none"> The JODI definition for kerosene includes Jet and other kerosene. The JODI definition includes other kerosene under Kerosene and not in Gas/Diesel Oil.

6. Estimations and Revisions of Data

6.1 Estimations

It is clear that it is preferable that all JODI data are submitted with real data, without any estimation. However, it is also possible that due to the size of certain flows and certain products, the data are either not collected on a regular basis, or they may exceptionally be missing for a certain time period.

6.1.1 Data are not collected

Estimates should only be used for flows and products which represent a small proportion in the oil balance, and which have the value of completing the major oil flows.

For example, if your country is a small exporter of LPG and this represents less than 10% of total exports on an annual basis, then it is feasible to include a monthly estimate for this flow and product in the JODI data. However, it is essential that the estimates are benchmarked periodically. This can be done by comparing monthly data to annual data or by comparing monthly data with information which becomes available with some time delay.

Please note that it is good practice to indicate which data have been estimated.

How to estimate?

- Establish the importance of the flow and product which needs to be estimated
- Work out if this flow/product is correlated with another flow for which you have data e.g. LPG exports are probably strongly correlated to either refinery production or NGL production
- Investigate if there is a seasonal trend for the flow/product
- Regular verification is essential

An example:

Country Z does not collect data for Total Oil Products, but has all the information for all flows for the products specified in the JODI. How can Total Oil Products be derived?

It is important to establish the size of the "Other products" in the oil balance. This can be determined by looking at a full balance of annual or quarterly data. The sum of the five petroleum products is lower than the Total Oil Products total, as "Other Products" are consumed in the country (e.g. lubricants, naphtha, paraffin waxes, etc.)

Estimations and Revisions of Data

Below is the annual oil balance of Country Z (Table 6.1). The last four columns show on the one hand, the sub-total of the five major products and their percentage share in the Total Oil Products and on the other hand, the size and percentage of the "Other Products" included in the Total.

Table 6.1: Annual Balance for Country Z

Unit: 1,000 Metric Tons

Petroleum Products						
Annual Balance		LPG	Gasoline	Kerosene	Gas/ Diesel Oil	Fuel Oil
Refinery Output		1050	10152	6680	23457	9019
Imports		1024	753	1328	13217	4163
Exports		228	2866	120	822	1461
Stocks	Closing Level	309	1504	738	5570	1608
	Change	9	-9	79	875	-71
Demand		2259	7270	5183	33350	6383

Annual Balance	Petroleum Products		Derived		
	Total Oil Products	Subtotal five Products	% of Total	Other Products	% of Total
Refinery Output	53790	50358	93.6%	3432	6.4%
Imports	22539	20485	90.9%	2054	9.1%
Exports	5770	5497	95.3%	273	4.7%
Stocks	10608	9729	91.7%	879	8.3%
	885	883	99.8%	2	0.2%
Demand	59848	54445	91.0%	5403	9.0%

From the above table, it can be derived that on an annual basis, the five major products account for 93.6% of refinery output and for 91% of demand.

Meanwhile, the "other products" account for 6.4% of refinery output and for 9% of demand. Given that the "other product" category accounts for less than 10 % in all flows, an estimate can be derived on a monthly basis in order to provide the total for Total Oil Products.

How to derive a monthly estimate?

Below is Country Z's submission for July 2006. There is no data for the "Other Products" demand, which will be estimated using Table 6.1.

Table 6.2: Monthly JODI data for Country Z

Unit: 1,000 Metric Tons

Petroleum Products						
Annual Balance		LPG	Gasoline	Kerosene	Gas/Diesel Oil	Fuel Oil
Refinery Output		88	846	557	1955	752
Imports		85	63	111	1101	348
Exports		19	239	10	69	125
Stocks	Closing Level	26	125	62	464	134
	Change	5	-12	7	73	-15
Demand		188	606	432	2779	532

Petroleum Products		Derived			
Annual Balance	Total Oil Products	Subtotal five Products	% of Total	Other Products	% of Total
Refinery Output	4483	4197	93.6%	286	6.4%
Imports	1878	1708	90.9%	170	9.1%
Exports	481	461	95.8%	20	4.2%
Stocks	884	811	91.7%	73	8.3%
	74	58	78.0%	16	22.0%
Demand	?	4537	91.0%	?	9.0%

If the monthly demand of the five major products (sub-total) is 4537 thousand metric tons, then the Total Oil Products (including the missing proportion for the Other Products) can be calculated using the percentage we derived from the annual balance.

We have determined that on a yearly basis the five major products account for 91% of demand in the country, therefore we can estimate Total Oil Products demand for this month as: $4537/0.91 = 4986$. (i.e. Subtotal Five Products / % of Total).

The missing "Other Products" account for $4986 - 4537 = 449$ thousand tonnes.

It is essential however, to establish that for none of the flows of the "Other Products" there is a strong seasonal trend; should there be, then the seasonality of the product needs to be taken into account when making the estimate.

6.1.2 Data are exceptionally not available

Although data may be collected on a regular basis, in some time periods, it is possible that a company does not report its data either on a timely basis, or for other reasons such as computer problems, staff changeover, etc. Unfortunately these occurrences happen in reality more often than hoped for and result in complications for the statistician.

How to estimate?

- Determine the different flows and products which the missing company usually reports
- Work out the average market share of the company compared with that of other companies for each flow and product
- Estimate the company's data on the basis of the other companies
- Alternatively, if the company's share has not been moving very much in the last year, use the same data reported for the corresponding month of the previous year
- In case there is no strong seasonality, and there is only one month missing, the previous month's data could also be used
- Use the trend of the total market as a measure to derive the company's data.

An example:

Country Z collects data from three different companies (A, B and C). Refinery B is late in providing its data for the month of November, but all the other companies have provided their data. The data for example, for gas/diesel oil is missing; in order to obtain some estimate there are various alternatives:

- the average share of the company in the total can be determined and used – see below

Table 6.3: Refinery Output of Gas/Diesel Oil of Country Z

Gas/Diesel Oil

Unit: 1,000 Metric Tons

	Sep-06	Oct-06	Nov-06	Average Company Share
Refinery Output	2400	2750	?	
<i>Company A</i>	720	880	775	31%
<i>Company B</i>	480	481	?	19%
<i>Company C</i>	1200	1389	1300	50%

To derive Company B's output, the share of company A and C are used. The output of company A and C is 2075 thousand tonnes, and this accounts for 81% (see Table 6.4)

Estimations and Revisions of Data

based on September and October data. Therefore the total is $2075/0.81=2562$, or company B's output is estimated as 487 thousand tonnes.

Table 6.4: How to Estimate Missing Data – Example 1

Gas/Diesel Oil				<i>Unit: 1,000 Metric Tons</i>	
	Sep-06	Oct-06	Nov-06	Average Company Share	
Refinery Output	2400	2750	2562e		
<i>Company A</i>	720	880	775	31%	
<i>Company B</i>	480	481	487e	19%	
<i>Company C</i>	1200	1389	1300	50%	
<i>Total A+B</i>			2075	81%	

- The same data as previous month or as same month previous year.

If the previous month's data is used, then the underlying assumption is that there is no strong seasonality between the two months, and that there is no major change in the company's output (e.g. there is no refinery maintenance plan in November 2006). See Example 1 in Table 6.4.

If seasonality is to be taken into account, then it is probably better to use the same month previous year's data (See Example 2 in Table 6.5). However, this means that other assumptions are made: that the company over the year has not increased or extended its refinery.

Table 6.5: How to Estimate Missing Data – Example 2

Gas/Diesel Oil				<i>Unit: 1,000 Metric Tons</i>	
	Nov-05	Sep-06	Oct-06	<i>Example 1</i> Nov-06	<i>Example 2</i> Nov-06
Refinery Output	2600	2400	2750	2556e	2525e
<i>Company A</i>	900	720	880	775	775
<i>Company B</i>	450	480	481	481e	450e
<i>Company C</i>	1250	1200	1389	1300	1300

So in the three examples above, three different results are obtained, depending on the underlying assumptions. **The quality of the estimates is of course only as good as the underlying assumptions are.** In the above case though, where total refinery output varies between 2525 and 2562, the difference in the total refinery output for gas/diesel oil only differs by 1.5% , which is much below the 5% error used as an acceptable standard in the JODI quality evaluation.

- A fourth possibility is to derive the company data using the total trend.

To apply this measure, it is necessary to assess whether the missing company in the past has followed the market trend. If over the past six months there is a very strong correlation between Company B's refinery output and the total refinery output, then the trend can be applied to company B's output.

Table 6.6: How to Estimate Missing Data – Example 3

Gas/ Diesel Oil		Unit: 1,000 Metric Tons						
	Nov-05	May-06	Jun-06	Jul-06	Aug-06	Sep-06	Oct-06	Nov-06
Refinery Output	2670	2600	2585	2500	2520	2425	2750	2794
Company A	860	900	885	875	865	800	880	900
Company B	450	450	450	425	430	425	481	472
Company C	1360	1250	1250	1200	1225	1200	1389	1422
% Change versus previous year								
Company A+C	-5.3%	-5.0%	-3.0%	2.5%	4.7%	5.2%	4.5%	4.8%
Company B	-4.7%	-4.6%	-4.0%	4.5%	5.0%	5.4%	4.0%	?

Company B's output here is estimated using the market trend, and applying a 4.8% growth rate to the November 2005 data. The result is $450 \times 1.048 = 472$.

The same method can be applied to other flows, e.g. production, demand and stock level data, but is less useful for trade, as the variability from month to month is much higher.

It has to be borne in mind that the above methods could not be used when the company's missing data has an overriding market share or dominates the market.

6.2 Revisions

Monthly data are very frequently revised, for many reasons, some of which may be that the companies work with provisional data and they may provide final data later in the year, or they may have discovered mistakes and corrected them. Moreover it is possible that there are new companies entering the market, which were not taken into account in first submissions.

The JODI questionnaire requests for data to be submitted for M-1 (last month) and M-2 (month before last). There is therefore, already a possibility to revise data provided for in the questionnaire. This however should not prevent countries/economies to submit revisions to monthly data for much earlier time periods.

Please note that when sending revisions for one month, this impacts the stock level data for the previous month (M-2). When stock level and changes are revised for September 2006, then it is very possible that the closing level for August 2006 was also revised, necessitating a submission for that month as well.

The JODI World Database aims to have monthly data as accurate as possible, starting from January 2002. The database is a live database and is updated monthly with the latest monthly submissions including also, with all the revisions member countries may have submitted.

7. Examples of Practices – A few Examples of JODI Data Collection and Methodology in Member Countries

The six international organisations asked some of their member countries to provide common practice of monthly oil data collection and to highlight their experience in dealing with bottlenecks and weaknesses in the data supply chain. Although it is recognized that each country may have unique and evolving data collection practices, it is still considered that some general guidance may be useful to other countries.

An understanding of the history behind the establishment of new data collection systems or adaptation of existing ones in support of the JODI, will raise awareness of the significant level of groundwork and ongoing commitment required to arrive at what may at first seem to be a simple 42 point top-level questionnaire response.

7.1 Argentina (data submitted to OLADE)

7.1.1 Data Collection

Argentina is a net oil importer. The legal framework of the country allows private investment in the sector and at present, exploration and exploitation activities are being developed by private investors. Around 50% of the national refining capacity is managed by Repsol-YPF.

In Argentina, there exists a national regulation that upholds the monthly oil information collection, related with production, internal and external markets, stocks, transformation processes at refineries (input/outputs) and demand.

Considering that several private companies operate in the country, the collection process for oil data becomes a little complex. Anyway, the presence of a legal enforcement for this activity, which establishes sanctions for time and format for non compliances, promotes submission of the information within short delays, which do not exceed three months.

Oil companies provide the required information through magnetic or graphic sources. The information related to refining inputs is received as balance formats. The company operator fills the form with "inputs" and "outputs" of the refinery and includes an automatic load balance, on which losses can not exceed a determined percentage. The balance is not automatically developed by product.

In Argentina, all the operations- imports and exports companies of oil and oil products are obliged to report their activities. There is no minimum oil volume restriction in order to report the information. It is estimated that the data reception is higher than 95%.

If an error or incoherence is detected with the data provided, contact with the source takes place in order to explain any misunderstanding. Anyhow, meetings with information providers are not common.

7.1.2 Data Processing and Overall Assessment of Collection System

The method used to insert the data is electronic for all the items in the JODI format, and its storage is done in the particular database. The data collection from the sources is not automatic.

The verification of the validity of the data consists only in assuring that the information comes strictly from the source. An automatic data consolidation is developed only for evident misbalances.

In the case of missing data, an estimation process is developed with a calculation that correlates the percentage variation of the same months of the previous year.

Normally, data is checked on a monthly basis and updated in the database each time it is received.

The information published is in the units required for internal analysis. If information on calorific values and densities are required, the sources are the manuals and publications of the oil ex - state company and conversion factors of OLADE.

In general terms, the collection system for monthly data for oil and products used in Argentina, can be defined as acceptable. The Legislation supports the data requirements of the companies, but the difference among data collection methods require different time periods for its processing and compliance control.

7.2 Croatia (data submitted to EUROSTAT)

7.2.1 Data Collection

There is legislation in Croatia covering all data flows in monthly oil data collection. The data are collected by means of monthly statistical surveys and from Customs tariff. The surveys are in a balance format. Different surveys are used for different flows.

The data sources and their share in collecting the corresponding data are the following:

- Monthly Survey on Industrial Production (IND-1/MPS form – these data are used also for industrial production volume indices) – 100%.
- Monthly special Survey on Oil Refineries (ERG-1N) – 100%.
- Monthly Survey on Imports, Exports and Stocks Change of Crude Oil and Petroleum Products (ERG-2N) – approximately 95%.
- From other sources - Customs tariff – approximately 5%.

The data providers are contacted to verify if mistakes / inaccuracies or suspicious numbers are noticed, but there are no regular meetings with them to discuss the methodology. Meetings are organised only as needed.

Mandatory data providers cover approximately 95% of the data.

Oil data is not collected for any other international or national purposes with different methodology than the one in JODI.

7.2.2 Data Processing and Overall Assessment of Collection System

The data are manually entered into the system, but there is no database.

The accuracy of the verification of the data is carried out by comparing the data with Customs tariff and with previous months. Also, logical control of data is carried out against expected lower and upper limits of flows of certain energy-generating products.

Usually, all data are collected and estimates are rarely made under the Customs tariff. Revisions to the data are accepted, but they are rarely incorporated.

The data are published in different units as needed. The IEA conversion factors are used.

The overall assessment of the data collection system is good. The coverage of the imports and exports data is 95%, and the coverage of the production data of oil derivatives is 100%

Suggested improvements include the following points:

The system could be better if there was a database in which all energy data, not only JODI data could be stored.

7.3 Egypt (data submitted to UNSD)

7.3.1 Data Collection

Egypt's first participation in the JODI project was in May 2002 in Mexico City. Since then, Egypt has strongly involved and adapted its system and processes to assure reporting quality data on time (which is M-1), and to achieve the best level regarding the main criteria for Data Quality Assessment, i.e. data coverage, completeness, timeliness and accessibility.

In order for Egypt to achieve M-1, it was essential to map its data flow processes. All unnecessary steps and bottleneck that cause delay were modified and eliminated. In the modified process, it currently takes 21 days to submit the data and to evaluate it in the Egypt Petroleum Corporation (EGPC). Currently, the whole data handling process takes about one month to report M-1 data.

The following is to summarize the main steps for the current data flow:

- The data flow starts from the fields and the companies to the concerned division in EGPC. Daily data checked, tabulated and loaded on the mainframe. Data are checked for coverage, completeness and up-loaded in specific format; necessary conversion is made to a standard format.
- Data are checked: the absolute value is graphically displayed; data comparison recognizes deviations, gaps and defined reasons for these gaps.
- Data are reported and delivered in the required report to the concerned higher levels.

7.3.2 Data Processing and Overall Assessment of Collection System

Data coverage: 95 oil companies are currently working in Egypt, with some of them in the private sector. 95% of the oil market currently reports data.

Data completeness: About 90% of the required data, such as crude oil and petroleum product production, export, import and demand are reported on a monthly basis. Stock level is not available on a monthly basis.

Data accuracy: Quality control is done through analysing the actual versus target values, and comparing data, including historical data, with the same period the year before. Also, assessing the currency of the data is done through the absolute and percentage deviations with $\pm 5\%$ tolerable deviation, which is acceptable level of estimation. In order to accelerate the data accuracy checks, data are required to be submitted in a balance format and checked with internal consistency. Data are currently controlled by the least three hierarchical levels.

Data Accessibilities: Through the existing network, data becomes easily accessible by users. It is also adequately documented and available in the form users desire.

Suggested improvements include the following points:

Still it is recognized that there are some criteria which need improvement such as completeness, raised level of data accuracy, standardized conversion factors, measurement's units between companies and provide adequate training for statistical analysis.

7.4 France (data submitted to IEA)

7.4.1 Data Collection

France has a legislation underpinning its monthly oil data collection. This covers all JODI data flows, i.e. production, imports, exports, stocks, refinery intake/output and demand: The 1992 French law on liberalization of the oil sector, which includes an article on oil statistics and the 2005 programme law setting the orientations of the energy policy. Other statistics stem from professional lobbies, which collect data from their members (e.g. oil distributors) on the basis of a gentleman's' agreement. These professional bodies publish data on markets, which are of great interest to their members. These bodies also provide many more services to their members. Therefore, participation of companies is good.

The sources of data are surveys on refinery activities (balance format + consistency control), crude oil import (consistency control) and deliveries (balance format). Estimations are also done (e.g. external trade for JODI M-1). A combination of surveys and other sources can also be used if, for instance, only annual data are available (petrochemical industry, etc)

There is a threshold of €150 000 per year or 1 tonne from which it becomes mandatory for all importers to report their data. Regarding LPG deliveries, there is a monthly survey for the companies' members of the CFBP (professional lobby) as well as an annual survey on non-members (= 1% of the total LPG deliveries). Other surveys are exhaustive.

Oil data is collected for other international or national purposes with different methodology than the one in JODI. The definition is different for crude oil imports and usually, companies use a different database to submit the JODI and the MOS (Monthly Oil Statistics). Moreover, for JODI, deliveries operated by storage facilities, are readily available whereas for MOS, it is companies' sales.

On average, there is no difference between sales and deliveries. Differences occur every month only because they are measured at different steps of the chain. Sales are preferred because they can be split by regions and because they correspond to financial flows.

When mistakes/inaccuracies or suspicious numbers are noticed, the French Authorities contact the data provider to verify. Regular meetings with data providers, users, and experts take place, and surveys are run together with the professional lobby- UFIP (Union Française des Industries Pétrolières).

7.4.2 Data Processing and Overall Assessment of Collection System

The method of data entry is mainly electronic for all flows and data are stored in two databases: ORNOIR and PEGASE. Methods for verifying data accuracy are very precise global controls on demand, according to climatic conditions, and other individual controls (controls on companies answers, see above). Missing data are estimated using two different methods:

- To estimate small figures, the previous data available;
- For large figures, estimation may be made more precisely, according to the past evolution, the number of days of the month, etc.

Data revisions are incorporated in the database at any time, but only if they are fully justified. Data are published in tonnes and in toe, using conventional conversion factors.

In general, the overall assessment of the French (JODI) oil monthly data collection system has been classified as good with the most important positive point being that its whole system utilises data that were already available, in 95% of the cases, for the activity of refineries, the achievement of a harmonization between their reporting systems and the one of the customs office. A negative point of the French JODI oil collecting system is that it relies on only one person.

Suggested improvements include the following points:

- Working data on foreign trade of products early enough for JODI.

7.5 Norway (data submitted to IEA)

7.5.1 Data Collection

Norway has a centralized organisation, where the national statistical office (Statistics Norway) is responsible for energy statistics in general and oil statistics in particular. The mandate of Statistics Norway is broad and does also cover energy statistics. Energy statistics is a sectoral statistics, similar to industrial statistics, trade statistics or agricultural statistics etc, which all have their role and are part of official statistics on their own while they also have to feed into the national accounts. Statistics Norway has its mandate defined by a Statistics Act, which enables them to access all relevant data from providers whom they find appropriate, including data from governmental institutions. This means that compiling oil and gas data on production, trade, stocks, refinery intake/output, demand, etc. is covered by the legislation.

The statistical office is not a user of statistics itself, but fulfils its mandate based on the needs in society. However, there are some indirect internal uses of oil statistics in producing the energy balance and the national accounts.

For inland consumption of petroleum products, the statistical act is not used, but Statistics Norway produces these statistics on behalf of the industry as a part of their needs. Statistics Norway is chosen because it is an independent actor with good production routines and systems. This is an example of how companies might be convinced to provide data in the absence of legislation.

The government regulates the oil business, and the Norwegian Petroleum Directorate (NPD), carries out the exercising role. Major players are, besides the NPD, relatively few retail companies, refineries and stock terminals. The system consists mainly of few large bodies, which makes a good overview, and short distance between the data providers and the statistical office. NPD collects all relevant data from the oil producing companies, which is forwarded to Statistics Norway. There is close cooperation between NPD and Statistics Norway, which is a huge advantage, due to their expertise and knowledge about the market.

At the time of the JODI reporting, figures for indigenous production from NPD are not final, neither are export figures, and a few stock figures may be missing for certain fields. The preliminary production figures from NPD are however quite accurate, and not far from the final reports. Missing crude oil and NGL stock figures from the NPD are estimated, by taking an average of the last 5 months. This is not a very accurate method, but it does not cause great deviations, as any missing stock figures usually are caused by minor fields. Crude oil and NGL export figures are for the JODI report collected from Statistics Norway's division for external trade, which base their statistics on custom bills. In addition, a smaller part of the NGL export figures are only available from the NPD as they are not covered by the customs. This is for the exports of Norwegian NGL from the

British sector. These have to be estimated at M-1, but as they are relatively stable from month to month, they put the figure from the previous month. All estimated figures are revised the next month, for the period M-2.

For inland consumption of refined petroleum products, a survey is used. The retailing companies report, by the 10th after the reference month, their sales of each product, distributed by the different consumer groups. This is done by using data files with a pre-defined format.

Refineries and terminals report production, consumption and stock figures by the 20th of each month after the reference month. This is reported in Excel spreadsheets, with formats defined by Statistics Norway.

Import/export data for refined products are collected directly from the database of the Division for external trade (which again comes from custom bills).

Production, export and stock figures for crude oil, NGL and natural gas from the upstream sector are reported in Excel spreadsheets from the NPD, and processed by Statistics Norway.

All import and export data is collected by the customs offices, and forwarded to Statistics Norway.

Distributors report their sales voluntarily, but they get reports from both the large actors and some minor players, which hold less than a percent. Loads imported by these distribution companies, are subtracted from the import volumes, to avoid double counting. The national distributors that reports voluntarily cover more than 95 per cent of all inland consumption, while the rest is net import from the foreign trade, and cannot easily be distributed on consumer groups.

Statistics Norway also reports Monthly Oil Statistics to IEA, mainly using the same methodology, despite the fact that this report is more detailed. By the time M-2 more data are final.

Norway, as a member of EUROSTAT, reports National Account figures. These include economic statistics for oil activity, which is collected by using a detailed set of questionnaires in an annual survey of the oil companies on the Norwegian Continental Shelf.

Oil data from the NPD is also collected by Statistics Norway's division for Environmental statistics, for use in the Environmental Accounts and in the Energy Accounts/Balances, and by the Division for Economic Indicators, for use in the production index. The different divisions collect different data, and use to some extent different processing methods and different definitions, but they keep internal consistency. The product definitions in the JODI-reports deviate from the product definitions in the National Accounts. This creates some confusion for their users, as the published figures are not always comparable, and it also creates some difficulties in international harmonization.

Mistakes, inaccuracies and suspicious numbers are currently followed up, by contacting the data providers. Statistics Norway has regular meetings with the branch organisation

for the sales companies where methodology is discussed. Further, they have a close relation and regular contact with the NPD.

7.5.2 Data Processing and Overall Assessment of Collection System

The method of data entry is manual, with extensive use of formulas in Excel spreadsheets. For inland consumption of products, data is kept in a database. Other data is kept in their original files.

Accuracy of data is verified by comparing with previous month, and by assessing reasonability. Furthermore, the internal users of oil data constitute an important part of the verification process, particularly in the work with the Energy Balance. To some degree, they estimate missing data. Missing stock figures for crude oil are estimated by using an average of the last 5 months, while missing import/export data for a smaller part of the total of NGL is estimated by using the figure for the previous month. Indigenous production figures for the period M-1 is estimated by the NPD, and is close to the final level.

In general, they do not revise monthly data. JODI data for M-1 is revised the next month for period M-2 and in the MOS. Final figures are reported annually in the AOS and AGS (respectively Annual Oil Statistics and Annual Gas Statistics), and might deviate from the sum of MOS. If deviation is due to errors in the processing, reports are revised. Minor deviations in consumption and production are not revised, as there will always be some disparity. Data on refined petroleum products are published in liters. Historical conversion factors are used to convert to tonnes. Other data are received in the required units.

Norway has a centralized administration for producing national oil production statistics in Statistics Norway, and the reporting units are to a great extent centralized. This makes a good overview of the sector. The few data providers make good possibilities for contact between Statistics Norway and the industry, and good possibilities for quality controls and checks. This gives them confidence that the data and the reports are of high quality.

Suggested improvements include the following points:

Statistics Norway is continuously working on improving the reports and their methods, and they are considering the possibilities of implementing a higher degree of automation. Using databases and programme applications would lighten the work, and increase the confidence. It would also facilitate revisions, as the reports are made manually today, with a high degree of separate calculations.

Also, reporting would be facilitated if the reports were built more like the annual reports; that is to say, with the possibility of reporting in time series. This would facilitate monthly revisions a lot.

7.6 Philippines (data submitted to APEC)

7.6.1 Data Collection

The Philippine downstream oil industry has been deregulated by virtue of Republic Act 8479, otherwise known as the "Downstream Oil Industry Deregulation Act of 1998". This law defined the policy of the State to liberalize and deregulate the Philippine downstream oil industry in order to ensure a truly competitive market under a regime of fair prices, adequate and continuous supply of environmentally-clean and high quality petroleum products.

The law and its implementing rules and regulations (IRRs), serve as the guidelines for the various petroleum downstream activities in the country. Figure 7.1 shows the flow of activities in the Philippine Downstream Oil Sector.

Figure 7.1 Downstream Oil Sector

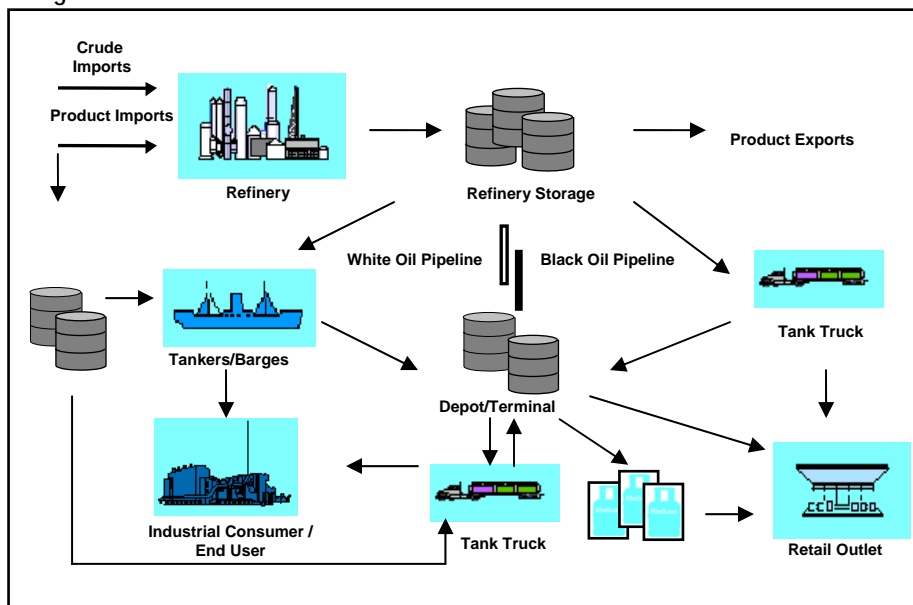

Downstream petroleum statistics are sourced directly from the participants in the industry and even importers for own use, e.g. airline companies. Rule II - Section 7 of the IRR requires the industry participants to submit various reportorial requirements to the OIMB (Oil Industry Management Bureau).

The monthly and annual reportorial requirements are submitted on or before the 15th day of the month following the month covered by the monthly report and not later than the

15th day of January of the year following the year covered by the annual report. These reports are submitted to OIMB through electronic mail, facsimile or directly delivered by messenger or via ordinary mail.

On the other hand, upstream data such as crude oil/condensate production and other upstream activity reports are covered by Presidential Decree 87, otherwise known as the "Oil Exploration and Development Act of 1972". The Energy Resource Development Bureau of the DOE (Philippines Department of Energy) is handling the monitoring activity for the petroleum upstream sector.

As part of its daily price monitoring functions, the DOE subscribes to oil-related information from an authoritative provider of energy information like Platts, which is an internet-based news and price assessment service. The DOE subscribes to Mean of Platts Singapore (MOPS) spot price for crude oil (Dubai) and refined petroleum products to understand price and market trends in the international market, and then relate this to the movements in the local oil industry.

The DOE seldom employs survey type of reports. However, through collaboration with other government agency (National Statistics Office), the DOE conducts the Household Energy Consumption Survey (HECS) every five (5) years. The primary objective of HECS is to gather data on household energy consumption, application and other relevant factors affecting such consumption.

The OIMB calls the attention of the player to the late submission of reports or non-compliance of the same. Failure to comply with submission of any reportorial requirements as provided under Chapter III - Section 12 of the Deregulation Act, penalizes any person, including but not limited to the chief operating officer or chief executive officer of the partnership, corporation or any entity involved, with imprisonment for two (2) years and fine ranging from Two Hundred Fifty Thousand Pesos (P250,000.00) to Five Hundred Thousand Pesos (P500,000.00). [One Peso was around 1.88 to 1.92 US cent in 2006.]

The Petroleum Institute of the Philippines conducts monthly meetings of its members and assists DOE as necessary.

In case of inaccuracies or suspicious numbers, the DOE asks the data provider to clarify and/or revise the questionable figures as the case may be.

There are other DOE units which submit reports (which include data from OIMB) to international institutions such as APEC, but with different report format, coverage (includes other energy sources) and units (metric tons) than that submitted by OIMB to JODI, which only cover data on oil. On the other hand, the DOE also provides data to other local government agencies e.g. Bureau of Customs (BOC), Central Bank of the Philippines – Development Budget Coordination Committee (DBCC) and the National Economic Development Authority (NEDA) among others.

However, as a matter of policy, the DOE only provides industry data per Section 15g of the "Downstream Oil Industry Deregulation Act of 1998", to observe confidentiality of data/information submitted and/or provided to the DOE, thereby encouraging the trust and confidence of data providers.

7.6.2 Data Processing and Overall Assessment of Collection System

Processing/entry of data is done manually and encoded in excel-based worksheets for consolidation. Database files are not yet available. However, the DOE, through its Information and Technology Management Services (ITMS) is currently studying on-line submission of reports of the oil players. The OIMB has also previously asked the ITMS to design a database programme for the consolidation and processing of downstream oil statistics.

Upon receipt of reports, the DOE verifies/evaluates the veracity of the monthly and annual reports submitted by the data providers by comparing these reports with their historical trends/records. Also, validation of import data reported, vis-à-vis submitted post shipping documents is also being done. Occasionally, the DOE also conducts visual inspections of the different crudes and petroleum products facilities to verify existing stocks, import arrivals and gather other relevant information as well. With the deregulation of the industry, however, some reports could not be validated and perhaps some numbers are not captured.

In case of missing data because of late and/or non-submission of reports of some data providers, an estimated figure is computed based on their yearly/monthly average data. Figures are revised with corrections incorporated upon receipt of the actual documents (i.e. final invoices) in the next monthly update.

The Philippine Energy Plan (PEP) which is regularly updated/published by the DOE provides for converted energy forms into a common unit, barrels of fuel oil equivalent (BFOE), based on fuel oil heating value equivalent at 18,600 BTU/lb. For OIMB's use, however, conversion factors available in such required documents as Bill of Lading are used.

Data coverage: With the deregulation of the Downstream Oil Industry since 1996, 186 additional new players (in various specific downstream activities) have joined the industry. This makes data collection more complicated with the increased number of reporting players as compared to only three (3) major oil companies previously existing during the regulated regime.

Data timeliness: With no definitive penalty for late submission of reports, some oil players would occasionally submit very late for one reason or another. Usually, there is one month back log in report collection and two months log for the processing and release of a final consolidated monthly report.

Data accuracy: New players would not initially fully understand some of the reports' requirement and would often submit inaccurate figures. Delayed availability of some final documents cause the data provider to submit estimated figures instead of actual; just to beat the specified deadline.

Suggested improvements include the following points:

- Strengthening enforcement authority of DOE. There is a proposed bill which seeks to address unjustified and/or delinquent compliance to the reportorial requirements through definitive penalties and restoration of DOE's authority and police power to suspend operations and revoke licenses of violators and to correct erring players in the industry. The existing provision only provides penalties for those who refuse to comply.
- Enhancing communication with data providers through constant coordination and cooperation, instilling the importance and significance of the generation and maintenance of timely, reliable and accurate oil statistics.
- Coordinating and cooperating with the ITMS to facilitate the database development and operation to further improve data collection, validation, processing, and report generation.
- Requesting for additional budget to improve/upgrade the existing computer network capability.

7.7 Saudi Arabia (data submitted to OPEC)

7.7.1 Data Collection

Saudi Arabia has a legislation underpinning its monthly oil data collection, which covers all JODI data flows, i.e. production, imports, exports, stocks refinery intake/output and demand. The sources for all data flows are surveys. Saudi (JODI) data are not collected in a balance format.

Oil exporters are obliged to report their data to Saudi Authorities. This regulation applies also to small volumes of traded oil; hence there is no minimum volume from which reporting becomes mandatory and all (100%) reported data is received on a mandatory basis. In cases of data mistakes or inaccuracies the country contacts the data provider for clarification. There are also regular meetings with data providers (once a year), which focus on the discussion of the data methodology.

7.7.2 Data Processing and Overall Assessment of Collection System

The method of data entry is electronic for all flows and all data are stored in a database.

Methods for verifying data accuracy are basic edit and range checks, comparisons to previous periods and flag reports if figures exceed a specified percentage tolerance. Missing data are (rarely) estimated by using different methods, which depend on the specific flow and product.

Data revisions are regularly received and are incorporated in the database on average four times a year. Data are also published/or received in different units – conversion takes place by the use of standard conversion factors at the country level.

In general, the overall assessment of the Saudi (JODI) oil monthly data collection system has been classified as very good with the most important positive points being its reliability, timeliness and its highly automatic functioning capability. A negative point of the Saudi JODI oil collecting system is its complexity.

Suggested improvements include the following points:

- Definitions need to be clarified, especially for stocks. This may come at the price of reduced simplicity but greatly enhances data quality.
- Desegregation of "total products" is needed: Many products are included in this category and every country deals with it in different ways that makes this particular figure incomparable.
- Additional flows are needed to be able to calculate balances such as other refinery intake and transfers.

8. The JODI World Database

8.1 Background

If the JODI World Database is the visible part of the Joint Oil Data Initiative, JODI is much more than collecting and releasing monthly oil statistics. JODI has played an important role in raising political awareness of the difficulties encountered in improving data reliability and timeliness. Networks have been established and statistical systems have been improved in many countries. Attitudes towards confidentiality and reliability have evolved. Contacts between oil companies, countries and organisations have multiplied. JODI has also strengthened producer-consumer dialogue by demonstrating that dialogue is not only a concept, but can lead to concrete action.

The release of the JODI World Database was not the primary goal of the initiative; however, since transparency is central to the initiative, the seven international organisations behind JODI - APEC, Eurostat, IEA, IEFS, OLADE, OPEC and UNSD - agreed to open the JODI World Database on the occasion of the inauguration of the new IEFS headquarters on 19 November 2005. This decision was taken with the full knowledge that users might be disappointed, as not all the data for all the flows, products and countries are always available, or of good quality.

The opening of the database is not the final goal of the initiative either. The database should improve continuously and several initiatives will soon be launched to further strengthen reporting expertise in countries and to raise political awareness.

8.2 Building the JODI World Database

The six international organisations responsible for the JODI data collection assemble their member country's data each month and send it to the IEFS. Data quality issues relating to member country's data are handled by each organisation, and each organisation is responsible for the data quality of its member country's data.

The IEFS gathers the data from the six organisations and carries out some additional checks. Moreover, data are converted into common units, so that they become comparable, as each organisation is collecting the JODI questionnaire data in the unit they use for other oil questionnaires.

Once data are verified and converted, the IEFS then updates, on a monthly basis the JODI World Database and makes it publicly available on the JODI website.

Figure 8.1: Relationship between the IEFS, International Organisations and Countries

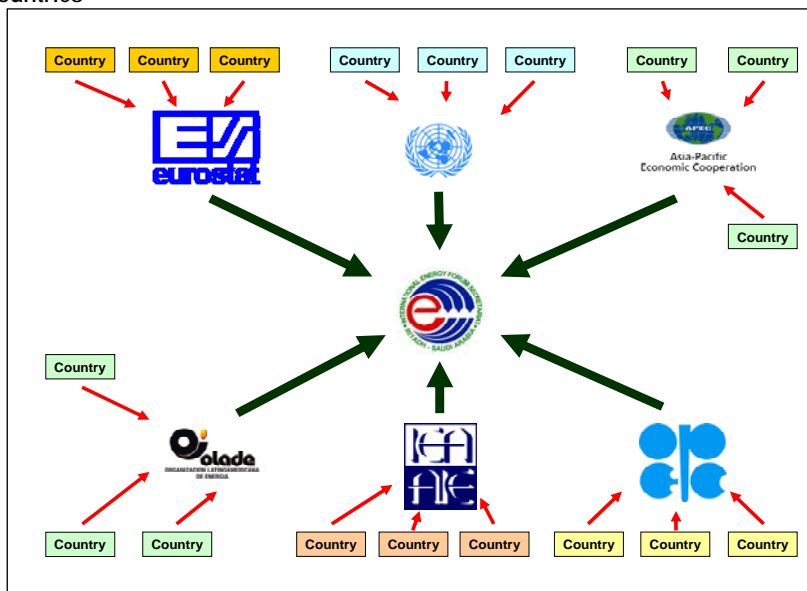

8.3 The JODI World Database

8.3.1 How to access?

The JODI World Database is accessible on the JODI Website. The website address is as follows: <http://www.jodidata.org>

Extensive background information as well as full explanations are provided on the website.

The data is presented using the Beyond 20/20™ browser software, available for downloading at the site.

8.3.2 What is included?

- Seven **product** categories: Crude Oil, LPG, Gasoline, Kerosene, Diesel Oil, Fuel Oil and Total Oil
- Four **flows**: As of the release in November 2005: Production, Demand, Closing Stock Levels and Changes. To be added are Refinery Intake and Refinery Output
- Data are available in three different **units** : barrels, tonnes and litres
- Conversion factors are available
- Data are for more than 90 participating **countries**
- History from January 2002, target is one month old

8.3.3 Some features

Transparency is the key word behind JODI; the database tries to be as transparent as possible:

- Choice to browse data online or download data files in Beyond 20/20 format
- Colour coding has been given to data cells to indicate the confidence evaluations of the data where possible (see below)
- Easy graphic representation
- Easy manipulation of products, flows and units
- Choice of language: English, French, German and Spanish
- Data downloadable in different formats, including the colour coding when downloading to Excel from a Beyond 20/20 format

Figure 8.2: A View from the Database

OTHER:	Unit - Thousand Barrels (kbb) ↕				Product - Total Products ↕				Balance - Demand ↕					
TIME	Jul2004	Aug2004	Sep2004	Oct2004	Nov2004	Dec2004	Jan2005	Feb2005	Mar2005	Apr2005	May2005	Jun2005	Jul2005	Aug2005
Country	↕	↕	↕	↕	↕	↕	↕	↕	↕	↕	↕	↕	↕	↕
Hong Kong	9,978	9,737	9,818	8,795	10,067	10,087	10,810	8,426	8,513	8,279	9,435	8,322	8,320	8,917
China	3,902	4,018	4,047	4,388	4,316	4,482	3,750	3,518	4,105	4,120	4,526	4,279	4,627	4,120
Hungary	645	1,118	533	510	630	105	653	345	615	263	548	518	698	0
Iceland	71,116	61,773	67,294	70,736	68,626	78,457	71,314	67,096	77,376	65,649	70,127	68,086	64,537	67,088
India	38,037	36,270	0	37,603	36,810	0	37,820	0	35,650	36,360	37,696	34,290	31,093	0
Indonesia	33,294	37,262	35,340	35,340	35,700	37,603	38,068	36,960	43,338	35,310	36,828	0	40,424	41,819
Iran (Islamic Rep.)	0	0	0	0	0	0	0	0	0	0	0	0	0	0
Iraq	4,762	4,790	5,191	5,473	4,881	5,670	5,121	5,339	5,945	4,952	4,938	5,530	4,649	5,241
Ireland	59,715	52,889	57,379	58,602	54,046	58,187	52,416	51,878	56,506	52,613	51,936	52,205	55,036	51,041
Italy	1,188	1,123	995	1,170	1,204	124	1,145	1,145	0	0	0	0	0	0
Jamaica	160,497	166,360	151,021	161,008	158,607	187,922	183,288	177,169	189,948	157,929	144,998	154,802	157,841	158,375
Japan	0	0	0	0	0	0	0	0	0	0	0	0	0	0
Kazakhstan	61,557	65,631	64,743	69,214	69,713	78,656	78,321	67,656	78,360	67,477	63,426	64,135	61,557	65,600
Korea	10,230	11,067	8,640	8,928	7,710	8,029	6,820	6,272	7,440	7,620	9,486	10,560	11,377	12,183
Kuwait	704	837	829	1,048	1,024	1,384	1,196	1,298	1,243	1,353	1,306	1,181	1,134	1,212
Latvia	5,983	6,293	5,550	6,634	6,660	6,386	7,533	6,356	7,285	7,080	7,006	6,780	0	0
Libya	1,775	1,947	1,939	1,837	1,697	1,861	1,533	1,548	1,736	1,689	1,775	1,767	1,814	1,986
Lithuania														

8.3.4 Colour coding

A unique colour cell feature provides the user with supplementary information on the assessment made:

- **BLUE:** A blue background indicates that results of the assessment show reasonable levels of comparability with other sources;
- **YELLOW:** a yellow background indicates that the Metadata should be consulted;
- **WHITE:** a white background indicates that data has not been assessed.

How was the colour coding derived? The assessment of the data was carried out on different levels:

- Comparability of the JODI data with other sources: monthly data from national and secondary sources has been assessed.
- JODI data have also been compared with annual data (when available) in order to check whether the levels and trends over the years could be confirmed.
- When no other sources were available for comparison with the JODI data, internal consistency and balance checks have been carried out.

Examples of internal consistency checks: the sum of all the reported products with reported figures for Total Oil Products is compared. When both - closing and stock changes data have been submitted - the consistency of the reported changes with the calculated ones is compared (See Chapter 5.2.2).

Example of balance check: The JODI questionnaire does not collect full balance information. However, some basic checks for reasonableness can be carried out, e.g. supply + import - export + stock change should have a relation with demand (See Chapter 5.2.1).

Remark: For IEA /OECD countries, data in the JODI database are the MOS data for all months except data shown for M-1. Comparability for the last month has been derived from comparison with MOS data. This methodology is applied using a rolling 12 month period.

8.4 Possible Future Expansion

For the time being, the database does not include data on refinery intake, refinery output, imports and exports. There are several reasons for this, including delays in obtaining the data. The missing flows could be made available in the future, depending on the timeliness, coverage and quality.

Annex 1: The Refinery Process

Crude oil in the state it is produced is not usable for most purposes. Although it can be burned directly in power generation plants, it cannot be used in cars or trucks.

To optimise the use of crude oil, it needs to be refined into several other products; this happens in a refinery. The market demand for oil products will not only dictate the optimal output of a refinery, but also, the type of crude which will be used and processed to produce the required output.

Crude oil is a mixture of many different hydrocarbons and small amounts of impurities. The composition of those raw materials can vary significantly depending on its source. Petroleum refineries are complex plants where the combination and sequence of processes is usually very specific to the characteristics of the raw materials (crude oil) and the products to be produced. A refinery takes crude oil and **separates** it into different fractions, then **converts** those fractions into useable products, and these products are finally **blended** to produce a finished product. These finished products are the fuels and chemicals used every day.

In a refinery, portions of the outputs from some processes are fed back into the same process, fed to new processes, fed back to a previous process or blended with other outputs to form finished products. One example of that can be seen in the chart below. However, refineries are different regarding their configuration, process integration, feedstock, feedstock flexibility, products, product mix, unit size and design and control systems.

Figure A1.1: Operation of a Typical Refinery

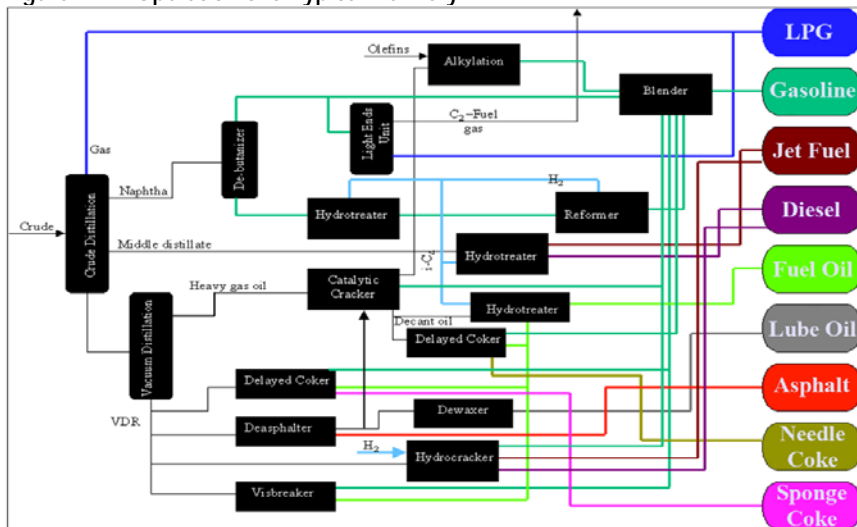

In addition, differences in owner's strategy, market situation, location and age of the refinery, historic development, available infrastructure and environmental regulation are amongst other reasons for the wide variety in refinery concepts, designs and modes of operation. The environmental performance can also vary from refinery to refinery.

The production of a large number of fuels is by far the most important function of refineries and will generally determine the overall configuration and operation. Nevertheless, some refineries can produce valuable non-fuel products such as feedstocks for the chemical and petrochemical industries. Examples are mixed naphtha feed for a steam cracker, recovered propylene, butylene for polymer applications and aromatics manufacture. Other specialty products from a refinery include bitumen, lubricating oils, waxes and coke. In recent years, the electricity boards in many countries have been liberalised allowing refineries to feed surplus electricity generated into the public grid.

Refining crude oil into usable petroleum products can be separated into two phases and a number of supporting operations. The first phase is desalting of crude oil and the subsequent distillation into its various components or 'fractions'. A further distillation of the lighter components and naphtha is carried out to recover methane and ethane for use as refinery fuel, LPG (propane and butane), gasoline blending components and petrochemical feedstocks. This light product separation is done in every refinery.

The second phase is made up of three different types of 'downstream' processes: combining, breaking and reshaping fractions. These processes change the molecular structure of hydrocarbon molecules either by breaking them into smaller molecules, joining them to form larger molecules, or reshaping them into higher quality molecules. The goal of those processes is to convert some of the distillation fractions into marketable petroleum products through any combination of downstream processes. Those processes define the various refinery types, of which the simplest is the 'Hydroskimming', which merely de-sulphurises and catalytically reforms selected outputs from the distillation unit. The amounts of the various products obtained are determined almost entirely by the crude composition. If the product mix no longer matches the market requirements, conversion units have to be added to restore the balance.

Market demand has for many years obliged refineries to convert heavier fractions to lighter fractions with a higher value. These refineries separate the atmospheric residue into vacuum gasoil and vacuum residue fractions by distillation under high vacuum, and then feed one or both of these outputs to the appropriate conversion units. Thus, by inclusion of conversion units, the product slate can be altered to suit market requirements irrespective of the crude type. The number and the possible combinations of conversion units are large.

The simplest conversion unit is the thermal cracker by which the residue is subjected to such high temperatures that the large hydrocarbon molecules in the residue convert into smaller ones. Thermal crackers can handle virtually any feed, but produce relatively

small quantities of light products. An improved type of thermal cracker is the coker, in which all the residue is converted into distillates and a coke product. In order to increase the degree of conversion and improve product quality, a number of different catalytic cracking processes have evolved, of which fluid catalytic cracking and hydrocracking are the most prominent. Recently, residue gasification processes have been introduced within refineries, enabling them to eliminate heavy residues completely and to convert them into clean synthetic gas for refinery use and production of hydrogen, steam and electricity via combined cycle techniques.

Annex 2: Units and Conversion Factors

Introduction

The most common units employed to express quantities of fuels and energy are those relating to volume, mass and energy. The actual units employed vary according to country and local conditions and reflect historical practice in the country, sometimes adapted to changing fuel supply conditions.

This annex will firstly, describe the various units in use and their interrelationships in general, and it will then provide for more specific information on units and conversion factors for oil.

1. Units and their interrelationships in general

The internationally recognised units which cover almost all of the measurements of fuel and energy quantities are the cubic metre, tonne (metric ton) and joule. These are the SI units.ⁱ However, over many years, other units have been used and the sections below will list their relationships where they are well defined.

1.1 Decimal system prefixes

The following table gives the most common multiple and sub-multiple prefixes used in oil statistics. Note that the prefixes should be used exactly as given. In particular, prefixes in lower case should never be written as upper case. For example, a figure expressing *x* kilowatts should be written as *x* kW, never *x* KW.

Table A2.1 Most Common Multiple and Sub-multiple Prefixes

10 ¹	deca (da)	10 ⁻¹	deci (d)
10 ²	hecto (h)	10 ⁻²	centi (c)
10 ³	kilo (k)	10 ⁻³	milli (m)
10 ⁶	mega (M)	10 ⁻⁶	micro (μ)
10 ⁹	giga (G)	10 ⁻⁹	nano (n)
10 ¹²	tera (T)	10 ⁻¹²	pico (p)
10 ¹⁵	peta (P)	10 ⁻¹⁵	femto (f)
10 ¹⁸	exa (E)	10 ⁻¹⁸	atto (a)

ⁱ They are derived from the metre, kilogramme and second included in the *Système International d'Unités* and serve as an international basis for science, technology and commerce.

1.2 Conversion equivalents

Units of volume

The unit of length underlies the unit of volume. 1 inch is *defined* as 25.4 millimetres. The gallon and litre were originally standards of liquid measure but are now formally defined in terms of the cubic metre. In the oil business, the barrel is the most frequently used unit of measure in North America, whereas the cubic metre is more frequently used in the Asia Pacific region.

Table A2.2 Conversion Equivalents between Units of Volume

To:	gal U.S.	gal U.K.	bbl	ft ³	l	m ³
From:	multiply by:					
U.S. gallon (gal)	1	0.8327	0.02381	0.1337	3.785	0.0038
U.K. gallon (gal)	1.201	1	0.02859	0.1605	4.546	0.0045
Barrel (bbl)	42.0	34.97	1	5.615	159.0	0.159
Cubic foot (ft ³)	7.48	6.229	0.1781	1	28.3	0.0283
Litre (l)	0.2642	0.220	0.0063	0.0353	1	0.001
Cubic metre (m ³)	264.2	220.0	6.289	35.3147	1000.0	1

Units of mass

The SI unit of mass is the kilogramme (kg) and the tonne (metric ton), equal to 1 000 kilogrammes, is widely used as the smallest unit in energy statistics. For most countries, the national commodity balances will use the kilotonne (1 000 tonnes) as the unit for presentation of commodities expressed in mass terms.

Table A2.3 Conversion Equivalents between Units of Mass

To:	kg	T	lt	st	lb
From:	multiply by:				
kilogramme (kg)	1	0.001	9.84×10^{-4}	1.102×10^{-3}	2.2046
tonne (t)	1000	1	0.984	1.1023	2204.6
long ton (lt)	1016	1.016	1	1.120	2240.0
short ton (st)	907.2	0.9072	0.893	1	2000.0
pound (lb)	0.454	4.54×10^{-4}	4.46×10^{-4}	5.0×10^{-4}	1

Energy units

The SI unit of energy is the Joule (J). Many other units for energy are in use for the practical expression of energy quantities, partly for historical reasons and partly because the small size of the joule demands the use of unfamiliar (for non scientists) decimal prefixes.

Historically, the tonne of coal equivalent was used but, with the ascendance of oil, this has been largely replaced by the tonne of oil equivalent (toe) *defined as 41.868 gigajoules*ⁱⁱ.

There are several other energy units in use; for example the *calorie* with a conversion equivalent between the calorie and the joule given by the International Steam Table (IT) which is defined to be 4.1868 joules. Similarly, the internationally agreed value for the British Thermal Unit (BTU) is now 1 055.06 joules. The BTU is the basis for the Quad (10^{15} BTU) and the Therm (10^5 BTU).

Table A2.4 Conversion Equivalents between Units of Energy

To:	TJ	Gcal	Mtoe	MBtu	GWh
From:	multiply by:				
TJ	1	238.8	2.388×10^{-5}	947.8	0.2778
Gcal	4.1868×10^{-3}	1	10^{-7}	3.968	1.163×10^{-3}
Mtoe	4.1868×10^4	10^7	1	3.968×10^7	11630
MBtu	1.0551×10^{-3}	0.252	2.52×10^{-8}	1	2.931×10^{-4}
GWh	3.6	860	8.6×10^{-5}	3412	1

2. Units and their interrelationships for oil

2.1 Mass and Volume

Oil is mostly measured by its **mass** or **volume**. Within each of these measurements, several units are used in the oil industry:

- The most widely used unit of **mass** (weight) to measure oil is the metric ton (or tonne). For instance, tankers in the oil industry are often described based on their capacity in tonnes, where an Ultra Large Crude Carrier (ULCC) is defined as being able to carry over 320,000 tonnes.
- The original unit for most liquid and gaseous fuels is **volume**. Oil can be measured by the litre, the barrel, or cubic metre. A common example of the use of volume as the unit of measurement is in the price of oil, quoted in dollars per barrel.

Because crude oil contains a wide range of hydrocarbons from the lightest to the heaviest, the characteristics including the density of individual crude oils vary greatly. Similarly, the density of the different petroleum products varies substantially between the products.

ⁱⁱ This is approximately the net calorific value of 1 tonne of crude oil.

The density can be used to classify petroleum products from light to heavy, where for example LPG is considered light at 520 kg/m³ while fuel oil is a heavy product at over 900 kg/m³.

To convert from mass into volume or vice versa, the specific gravity or density of the oil must be known. Without going into too much technical detail, a few terms need to be explained in order to understand oil conversion factors.

Density is defined as mass per unit volume, i.e. tonne/barrel. The **specific gravity** is the relative weight per unit volume (or density) of a given substance compared to that of water. The density of water is 1g/cm³. Motor gasoline for example has a lower density as it is much lighter for the same volume. The specific gravity of motor gasoline is therefore smaller than 1. Since volume changes with changes in temperature, data on specific gravity are made with a reference to a specific temperature (for petroleum, the reference is usually 15 degrees Celsius). Moreover, specific gravity is often quoted as a percentage e.g. a specific gravity of 0.89 is shown as 89.

The term **API gravity** (a standard adopted by the American Petroleum Institute) is commonly used to express the specific gravity of petroleum.

For information, API gravity is defined as: $(141.5 / 60^{\circ} \text{ specific gravity at } 60^{\circ} \text{ F}) - 131.5$.

The result is an arbitrary scale for measuring gravity, expressed in degrees API, where the lighter a compound is, the higher its degrees of API gravity. For example, what are considered light crudes are generally greater than 38 degrees API, while those with less than 22 degrees API are labelled as heavy crude oils.

Specific gravity and API gravity move in opposite directions. API gravity moves in the same direction as energy content per tonne (metric ton), i.e. the higher the API gravity, the higher the energy content per tonne, whereas specific gravity moves in the same direction as energy content per unit volume.

The *JODI Questionnaire* requires oil data to be reported in the unit which your international organisation has adopted, e.g. for OPEC member countries this is in volume units (barrels), for IEA this is in mass (metric tons).

This sometimes necessitates for national statisticians to convert volumetric data into metric tons (or conversely). To the extent possible, information should be obtained from the reporting enterprises on how quantities of crude oil and petroleum products have to be converted from volume to metric tons.

This is particularly important for some of the oil products in gaseous form (e.g. Refinery Gas, Ethane, LPG) which have to be expressed in mass terms.

Below is a table showing typical or average densities, calorific values and derived conversion factors for crude oil and the main oil products.

Table A2.5 Typical Densities, Conversion Factors and Calorific Values for Crude Oil and Petroleum Products (JODI products are in blue).

Product	Density kg/m ³	Litres per metric ton	Barrel per metric ton	Gross Calorific Value (GJ/t)	Net Calorific Value (GJ/t) (3)
Crude Oil	853	1172	7.37	45.00	47.37
Ethane	366	2730	17.17	51.90	47.51
Refinery Gas	786	1272	8.00	52.00	47.60
Propane	508	1969	12.38	50.32	46.33
Butane	585	1709	10.75	49.51	45.72
LPG (1)	539	1856	11.67	50.08	46.15
Naphtha	706	1416	8.91	47.73	45.34
Aviation Gasoline	707	1414	8.90	47.40	45.03
Motor Gasoline (2)	741	1350	8.49	47.10	44.75
Jet Kerosene	803	1246	7.84	46.93	44.58
Other Kerosene	810	1235	7.76	46.05	43.75
Gas/ Diesel Oil	844	1186	7.46	45.66	43.38
Fuel Oil Low Sulphur	925	1081	6.80	43.75	43.38
Fuel Oil High Sulphur	975	1026	6.45	42.00	43.38
Bunker Fuel Oil	975	1026	6.45	42.60	40.47
Fuel Oil (Avg)	944	1059	6.66	42.82	40.68
White Spirit	743	1346	8.46	46.32	44.00
Paraffin Waxes	801	1248	7.85	42.00	39.90
Lubricants	887	1127	7.09	44.00	41.80
Bitumen	1035	966	6.08	42.10	40.00
Petroleum Coke	1150	870	5.47	34.80	33.06
Other Products	786	1273	8.00	42.30	40.19

(1) Assumes a mixture of 60% propane and 40% butane by mass.

(2) An average for motor gasolines with RON between 91 and 95.

(3) For Naphtha and heavier oils the net calorific value is assumed to be 95% of gross.

2.2 Daily versus Monthly data

One other problem the statistician is faced with sometimes, is that the unit used by the oil industry in the country is on a daily basis e.g. barrels per day and data need to be converted to a monthly basis.

The following table offers an example of converting volume (in this case given in barrels per day) to mass (in metric tons) for two different months, e.g. January and February.

Table A2.6 Example of Converting Volume to Mass

Imports	Reported data in barrel per day (volume)	Number of days in Month	Density: Mass/Volume (tonne/m ³ -Average)	Volume/Mass Barrel per Tonne Conversion Factor	Conversion into Metric Tons (Mass)
Crude Oil	1020	31	0.853	(1/0.853)/0.159*=7.37	(1020x31)/7.37=4290
Motor Gasoline	546	28	0.741	(1/0.741)/0.159*=8.49	(546x28)/8.49=1801

(*) 1 barrel = 159 litres

List of Abbreviations

APEC	Asia Pacific Economic Cooperation
API gravity	American Petroleum Institute gravity
ARA	Amsterdam - Rotterdam - Antwerp
b/d	barrels per day
bbf	barrel
bcm	billion cubic meters
BFOE	Barrel of Fuel Oil Equivalent
BTU/lb	British Thermal Unit per pound
CFBP	Comité Français du Butane et du Propane
cSt	centistoke
EBV	German Oil Storage Association
Eurostat	Statistical Office of the European Communities
Gcal	Giga calories
GWh	Giga Watt hour
IATA	International Air Transport Association
IEA	International Energy Agency
IEFS	International Energy Forum Secretariat
J	Joule
JODI	Joint Oil Data Initiative
kg/l	kilogrammes per litre
kg/m ³	kilogrammes per cubic meter
LNG	Liquefied Natural Gas
LPG	Liquefied Petroleum Gas
M-1	Read as M minus one: the month previous to the current month
M-2	Read as M minus two: two months previous to the current month
MOS	Monthly Oil Statistics
Mtoe	Million tonnes of oil equivalent
NATO	North Atlantic Treaty Organisation
NPD	Norwegian Petroleum Directorate
OLADE	Latin-American Energy Organisation
OPEC	Organisation of Petroleum Exporting Countries
RON	Research Octane Number
SBP	Industrial Spirit
SEATO	South East Asia Treaty Organisation
SI Units	Système International d'Unités
SPR	Strategic Petroleum Reserve
TJ	Tera Joule
toe	tonnes of oil equivalent
UFIP	Union Française des Industries Pétrolières
ULCC	Ultra Large Crude Carrier
UNSD	United Nations Statistics Division

Contact Details

Asia Pacific Economic Cooperation (APEC) www.iecej.or.jp/egeda

Shigeru Kimura
Senior Research Fellow
INUI. Bldg Kachidoki, 13-1, Kachidoki 1-Chome, Chuo-Ku
Tokyo 104-0054, Japan
e-mail: kimura@edmc.iecej.or.jp

Statistical Office of the European Communities (EUROSTAT) app.eurostat.ec.europa.eu

Pekka Loesoenen
BECH Building, 5, rue Alphonse Weicker
L-2721 Luxembourg
e-mail: Pekka.loesoenen@ec.europa.eu

International Energy Agency (IEA) www.iea.org

Jean-Yves Garnier
Head, Energy Statistics Division
9, rue de la Federation
75739 Paris Cedex 15, France
e-mail : jean-yves.garnier@iea.org

International Energy Forum Secretariat (IEFS) www.iefs.org.sa

Said Nchet
Energy Director
Diplomatic Quarter
P.O. Box 94736, Riyadh 11614, Saudi Arabia
e-mail: said.nchet@iefs.org.sa

Latin-American Energy Organisation (OLADE) www.olade.org.ec

Mauricio Garron
Director of Strategies and Projects
Av. Mariscal Sucre No. N58-63 & Fernandez Salvador, OLADE Bldg
P.O. Box 17-11-6413 Quito, Ecuador
e-mail: mgarron@olade.org.ec

Organisation of Petroleum Exporting Countries (OPEC) www.opec.org

Fuad Al-Zayer
Head, Data Services Department
Obere Donaustrasse 93
A-1020 Vienna, Austria
e-mail: fzayer@opec.org

United Nations Statistics Division (UNSD) www.un.org/depts/unsd

Karoly Kovacs
Chief, Energy Statistics Section
2 UN Plaza, DC2-1414
New-York, NY 10017, USA
e-mail: kovacs@un.org

Comments can also be sent at the following e-mail address: jodinfo@iefs.org.sa

Cover design, layout and printing by



DEPPS, Saudi Arabia
depps@estefa.com
+966 1 464 5 464
www.estefa.com

JODI MANUAL

Ministers identified at the 7th IEF in Riyadh, in 2000, the lack of transparent, reliable and timely oil market statistics as one of the key contributory factors to volatility of oil prices. As a concrete manifestation of the dialogue, six international organisations – APEC, Eurostat, IEA, OLADE, OPEC and UNSD – took up the challenge, combined their efforts, involved their Member Countries and, in April 2001 launched a project which is now firmly established under the co-ordination of the IEFs as the Joint Oil Data Initiative (JODI).

Transparency remains high on the agenda of policy-makers worldwide and the process has gathered momentum with more than 90 participating countries providing data on more than 90% of global supply and demand. The process to improve timeliness, accuracy and completeness of data was given further impetus when the JODI World Database was made available as a public resource in November 2005.

The partner organisations and their Member Countries are committed to the process, and the ongoing success of JODI relies on the sustained and active participation and support of all key players – organisations, countries, oil companies and analysts.

The JODI Manual is a training tool designed to disseminate the data transparency message and clarify the definitions and methodologies utilised in the submission of JODI data. It is a living document and feedback is an essential element in the drive for progress. Comments and suggestions are actively encouraged.



International Energy Forum Secretariat

Asia Pacific Economic Cooperation



Latin American Energy Organisation

Statistical Office of the European Communities



Organisation of Petroleum Exporting Countries

International Energy Agency



United Nations Statistics Division